



User Manual

XM Octal I/O

Dual 8 Port Rack
Mounting Connector Panel
For Octal I/O IndustryPack[®]s

XM-Octal I/O

Dual 8 Port Rack Mounting Connector Panel For Octal I/O IndustryPacks

This document contains information of proprietary interest to GreenSpring Computers. It has been supplied in confidence and the recipient, by accepting this material, agrees that the subject matter will not be copied or reproduced, in whole or in part, nor its contents revealed in any manner or to any person except to meet the purpose for which it was delivered.

GreenSpring Computers has made every effort to ensure that this manual is accurate and complete. Still, the company reserves the right to make improvements or changes in the product described in this document at any time and without notice. Furthermore, GreenSpring Computers assumes no liability arising out of the application or use of the device described herein.

GreenSpring's products are not authorized for use as critical components in life support devices or systems without the express written approval of the president of GreenSpring Computers, Inc.

The electronic equipment described herein can radiate radio frequency energy. Operation of this equipment in a residential area is likely to cause radio interference, in which case the user, at his own expense, will be required to take whatever measures may be required to correct the interference.

GreenSpring Computers
1204 O'Brien Drive
Menlo Park, CA 94025
(415) 327-1200
(415) 327-3808 FAX

IndustryPack is a trademark of GreenSpring Computers, Inc.
1993 © GREENSPRING COMPUTERS, INC.

Table of Contents

- 1. General Product Description5
- 2. Model Numbers5
- 3. Inspection, Warranty, and Repair.....6
- 4. Specifications.....7
- 5. Installation and Jumper Options.....8
- 6. D9 to DB25 Translation..... 13
- 7. Accessories 14

List of Figures

1.	J1 and J2 Interface Connectors.....	8
2.	Default Jumpering	8
3.	Default D9 Output	9
4.	Null Modem Jumpering (RS-232).....	9
5.	Null Modem Output (RS-232).....	9
6.	Null Modem Jumpering (RS-422).....	10
7.	Null Modem Output (RS-422).....	10
8.	Jumper Group Pinout (RS-232).....	11
9.	Jumper Group Pinout (RS-422).....	12
10.	Basic Pinout of D9 Connector.....	12
11.	D9 to DB25 Translation.....	13
12.	D9 to DB25 Adaptor.....	14
13.	IP 50 Cable.....	14

General Product Description

The GreenSpring Computers IP-Octal Distribution Panel operates with Octal format IndustryPacks IP-Octal Serial and IP-Octal 422. Each panel interfaces up to two IndustryPacks to industry standard D9 connectors. Each D9 connector can be configured meet individual channel requirements. The D9 output emulates the IBM-PC/AT style output for RS-232. These signal names are provide in Figure 9 of this manual.

The IP-Octal Distribution Panel is rack mountable into most standard 19" cabinets and only requires 1U (43.6mm) of rack space. Some mounting hardware is provided for your convenience. D9 to DB25 adapter cables are available in groups of eight. These adapters are shown in figure 10 in this user manual.

Inspection, Warranty, and Repair

Upon receipt, carefully inspect the IP-Octal Distribution Panel and shipping container for evidence of damage in shipping. Notify the factory immediately if shipping related damage is suspected.

Limited Warranty

GreenSpring Computers warrants this product to be free from defects in workmanship and materials under normal use and service and in its original, unmodified condition, for a period of one year from the time of purchase. If the product is found to be defective within the terms of this warranty, GreenSpring Computers' sole responsibility shall be to repair, or at GreenSpring Computers' sole option to replace, the defective product, provided the product is returned shipping prepaid and insured to GreenSpring Computers. All replaced products become the sole property of GreenSpring Computers.

GreenSpring Computers' warranty of and liability for defective products is limited to that set forth above. GreenSpring Computers disclaims and excludes all other product warranties and product liability, expressed or implied, including but not limited to any implied warranties of merchantability or fitness for a particular purpose or use, liability for negligence in manufacture or shipment of product, liability for injury to persons or property, or for any incidental or consequential damages.

GreenSpring's products are not authorized for use as critical components in life support devices or systems without the express written approval of the president of GreenSpring Computers, Inc.

Service Policy

Before returning a product for repair, verify as well as possible that the suspected unit is at fault. Then call the factory for a RETURN MATERIAL AUTHORIZATION (RMA) number. Carefully package the unit, in the original shipping carton if this is available, and ship prepaid and insured with the RMA number clearly written on the outside of the package. Include a return address and the telephone number of a technical contact. For out-of-warranty repairs, a purchase order for repair charges must accompany the return. GreenSpring Computers will not be responsible for damages due to improper packaging of returned items.

Out of Warranty Repairs

Out of warranty repairs will be billed on a material and labor basis. The current minimum repair charge is \$100. Customer approval will be obtained before repairing any item if the repair charges will exceed one third of the quantity one list price for that unit. Return transportation and insurance will be billed as part of the repair and is in addition to the minimum charge.

Specifications

Capacity:	16 Channels of RS-232 or RS-422
Connector type	D9 Female IBM-PC/AT D9 Serial I/O output
Signals supported	
RS-232	RX, TX, RTS, CTS, DTR, DCD, DSR, RI, GND
RS-422	TX+, TX-, RX+, RX-, GND
Size, inch:	18.99 w 1.72 h 1.5 d
Weight:	1.45 lbs

Requires 50 pin ribbon cable (one per IndustryPack) and an IP-Octal Serial or IP-Octal 422

Installation and Jumper Options

The Octal panel can be mounted in a standard 19" rack with the provided hardware (4, 10-24 x 1" machine screws).consult the rack manufacturer if the provide hardware is not sufficient for installation.

IndustryPacks can be connected via a 50 pin flat cable to J1 and J2 (located on the back side of the panel). Be careful to put pin 1 in the right location. (The IP-50 cable is keyed to prevent incorrect installation)

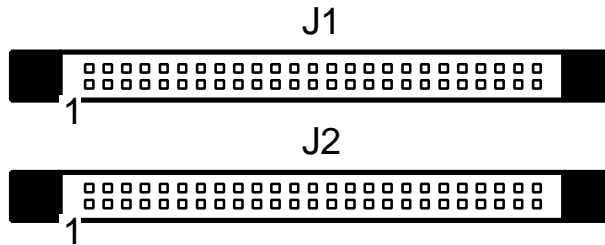

Figure 1, IP-Distribution connectors as viewed from unit back

Each channel of the Octal panel can be configured to meet individual needs. Each channel has a corresponding 16 pin jumper block. Factory default settings are shown below.

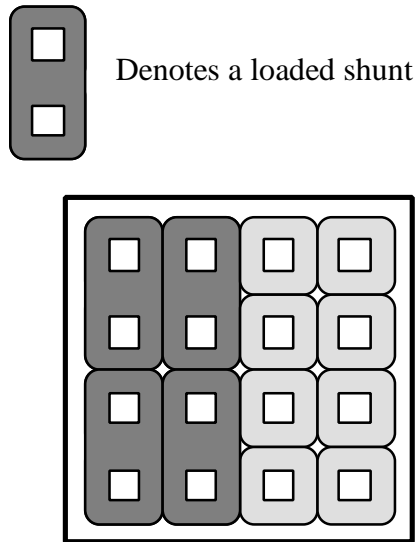

Figure 2. Default jumpering of the Octal Panel

The above jumper setting will allow connection to DCE equipment. The pin assignment on the D9 connector will be as follows:

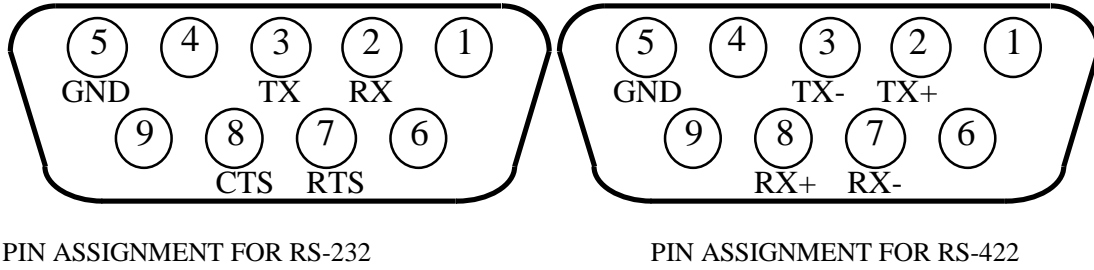

Figure 3. Default D9 output

To allow connection to DTE RS-232 equipment, the following jumper setting is required:

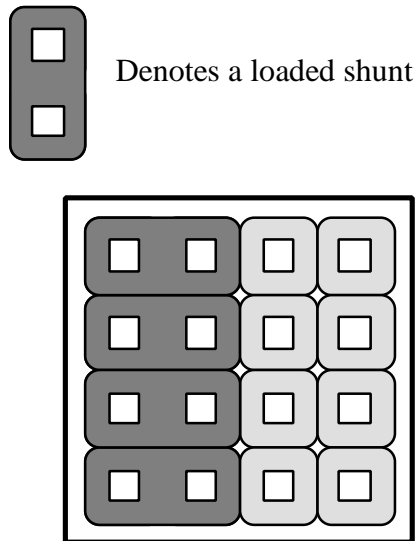

Figure 4. Null modem setting RS-232

The above jumper setting will assign pins on the D9 connector as follows :

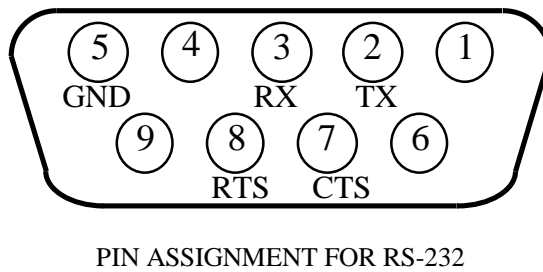

Figure 5. Null Modem Output RS-232

To allow connection to DTE RS-422 equipment, the following wire wrapping is required:

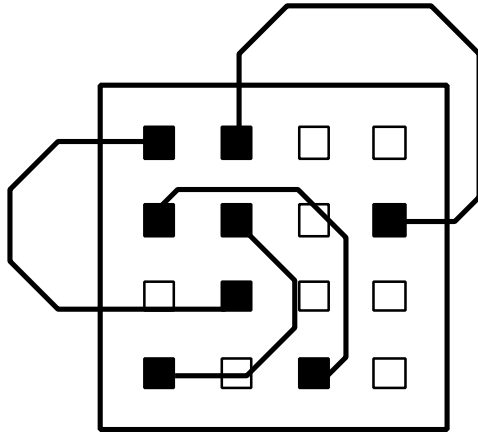
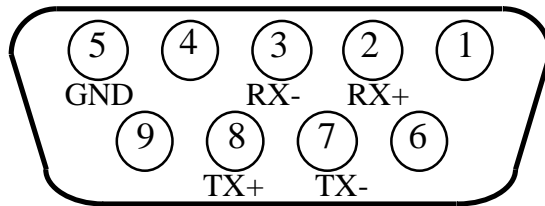

Figure 6. Null modem setting RS-422

The above jumper setting will assign pins on the D9 connector as follows :



PIN ASSIGNMENT FOR RS-422

Figure 7. Null Modem Output RS-422

The Octal panel can also be jumpered to support the following signals standard to some RS-232 equipment:

- DCD** (Data Carrier Detect)
- DTR** (Data Terminal Ready)
- DSR** (Data Set Ready)
- RI** (Ring Indicator)

Figure 8 shows the Pinout for the jumper blocks when connected to the IP-Octal serial (RS-232). The pins have been configured to provide the maximum amount of options with the use of shunt. If shunts are not available or the configuration required cannot be achieved with shunts, standard wire-wrapping can be done.

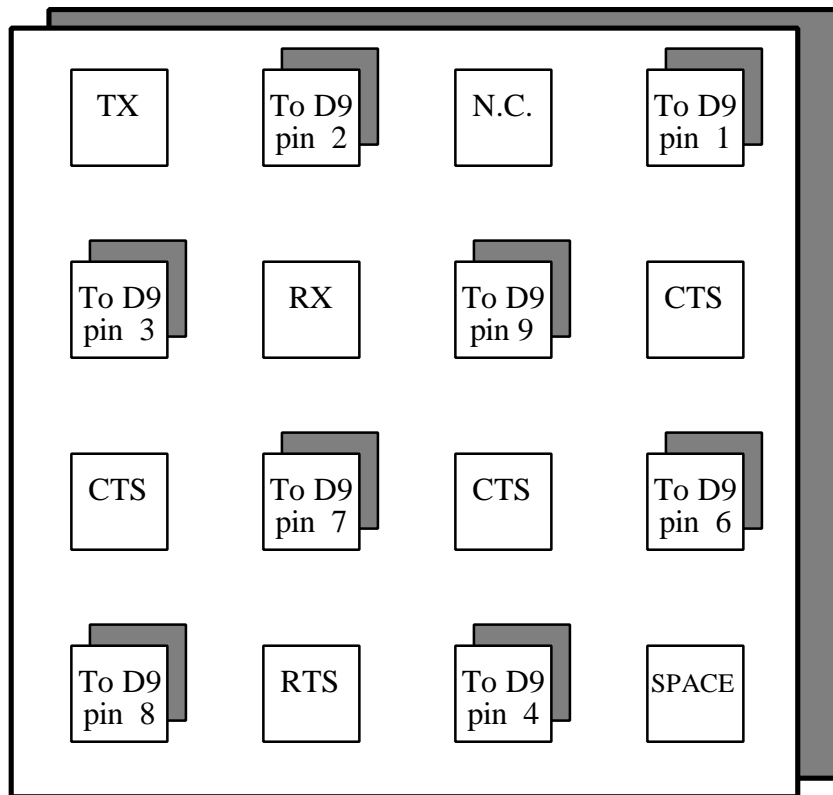

Figure 8. Jumper group pinout for RS-232

Figure 9 shows the Pinout for the jumper blocks when connected to the IP-Octal 422 (RS-422).

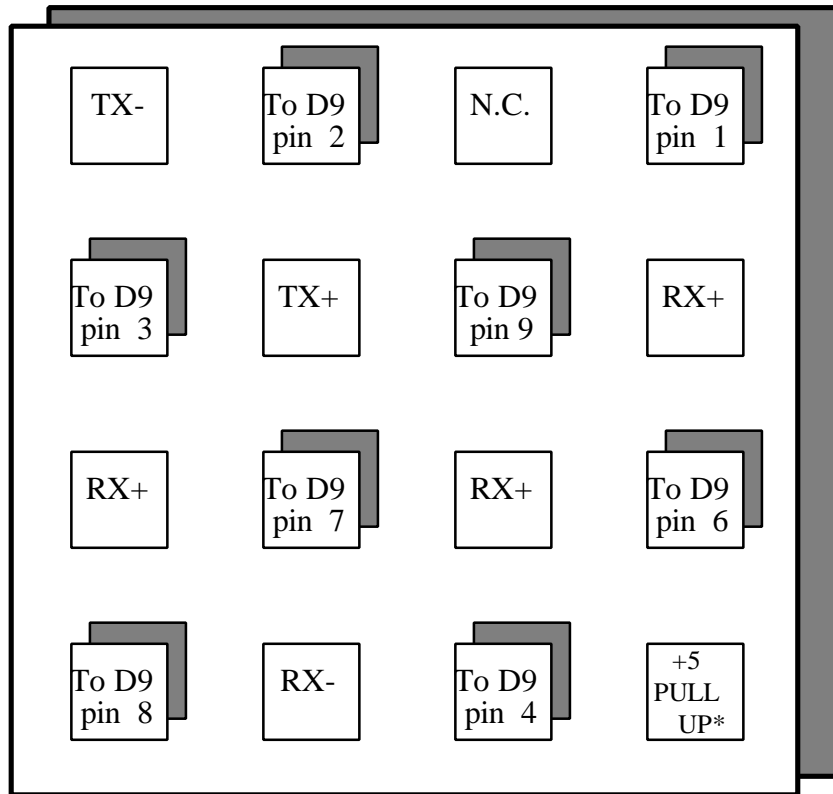

Figure 9. Jumper group pinout for RS-422

* Please note that the +5 pull up signal is a function of the installed Industry Pack. This signal is available through pin 42 of the IP's I/O connector. Refer to your IP-Octal documentation to verify that +5 volts is available on this pin.

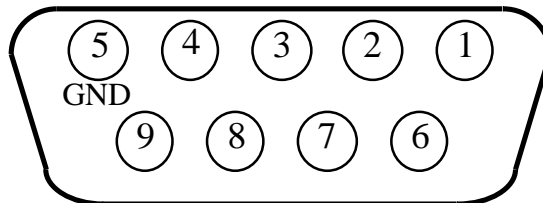

Figure 10. Basic pin out of D9 Female connectors

D9 to DB25 Translation

The following chart shows the industry standard RS-232 signals for the D9:

D9	DB25	Signal Name
1	8	DCD (Data Carrier Detect)
2	3	RX (Receive Data)
3	2	TX (Transmit Data)
4	20	DTR (Data Terminal Ready)
5	7	GND Ground
6	6	DSR (Data Set Ready)
7	4	RTS (Request To Send)
8	5	CTS (Clear To Send)
9	22	RI (Ring Indicator)

Figure 11. D9 to DB25 Translation