



# NextStep™

Microstepping  
Drive

*“Twice the Power  
at Half the Size”*

**Quick  
Setup**   
& Reference

## Table of Contents

Connecting Your Motion Controller.....	1
Connecting Your IDC Stepper Motor....	2
NextStep Drive Settings.....	3
Mounting the NextStep.....	4
Fine-Tuning Your NextStep.....	5



For more information contact: Industrial Devices Corporation - 3925 Cypress Dr., Petaluma, CA 94954  
(800) 747-0064 - FAX (707) 789-0175 - Outside the U.S. (707) 789-1000 - web: [www.idcmotion.com](http://www.idcmotion.com)

P/N PCW-4930 Revision 1.5 8/99

# Connecting Your Motion Controller

## External Connections



## Internal Circuits

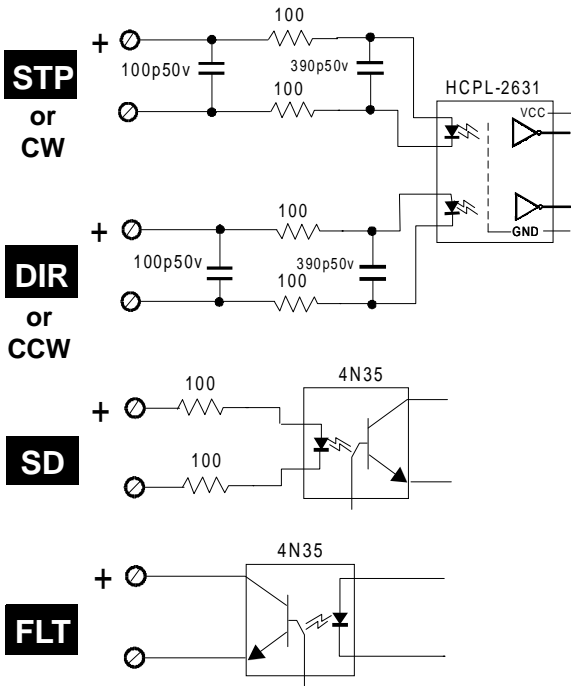

Signal	Current	Voltage	Other
Fault	50 mA Max.	Up to 30VDC	Normally Conducting Open on Fault
Shutdown	5-15 mA	*5VDC	High = Enabled
Direction or CCW	5-15 mA	*5VDC	Setup time: 250nsec Min. ON & OFF Time
Step or CW	5-15 mA	*5VDC	Max. Frequency: 2 MHz

**Note:** Connect shield of cable to one end only. The earth ground terminal on the NextStep is provided for this purpose. **\*External current-limiting resistor required for 12V or 24V connections. Use 560ohm, 1/4 W for 12V connection. Use 1.3Kohm, 1/2W for 24V connection.**

# Connecting Your IDC Stepper Motor



## In Series

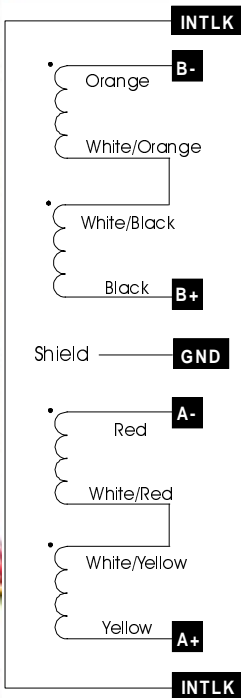

## In Parallel

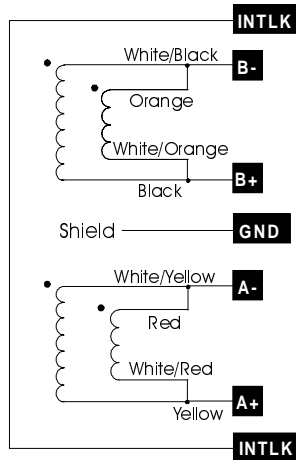

Quick  
Disconnect  
Cable  
P/N QF3-12

Wire Color on Quick Disconnect Cable	NextStep Connection
Red w/ Black	B-
Red w/ White	B+
Green	*GND
Red w/ Yellow	A-
Red	A+

\*Connect shield of new gray QF3-12 cable to GND as well.

# NextStep Drive Settings

## DRIVE SETTINGS

	IDC MOTOR	CURRENT		Inductance ON=Low OFF=High  (See Note)	Unloaded Anti-Res	
		@120	@240		Dial	Switch
SERIES (T)	S21	1.2	*1.2	OFF	0	OFF
	S22	1.5	*1.5	OFF	2	OFF
	S23	1.7	*1.7	OFF	5	OFF
	S32	2.8	*2.8	OFF	8	OFF
	S33	3.5	*3.5	OFF	9	OFF
	S42	6.0		ON	E	OFF
	P31		1.5	OFF	3	OFF
	P32		1.6	OFF	6	OFF
	P33		2.0	OFF	8	OFF
	P41		2.8	OFF	9	OFF
	P42		3.3	OFF	C	OFF
	K42		3.2	OFF	D	OFF
PARALLEL (V)	S21	*2.3		ON	3	OFF
	S22	*3.0		ON	6	OFF
	S23	*3.4		ON	8	OFF
	S32	*5.6		ON	C	OFF
	S33	*7.0		ON	D	OFF
	S42	7.9		ON	3	ON
	P31	2.9		OFF	7	OFF
	P32	3.3		OFF	A	OFF
	P33	4.0		OFF	C	OFF
	P41	5.7		OFF	D	OFF
	P42	6.6		OFF	1	ON
	K42	6.4		OFF	2	ON



**REST:** The **ON** setting reduces motor current to 1 amp after no motion has occurred for 12 minutes. Full current will resume upon receipt of next step pulse. Reduces drive & motor temp.

**IDLE:** The **ON** setting reduces current to 75% of drive setting if no step-pulses are received for 10 ms. Full current will resume upon receipt of next step pulse. Reduces drive & motor temp.

**WAVEFORM:** Changes shape of current waveform. Default is sinusoid. **ON** setting changes waveform to -4% 3rd harmonic. Optimizes smoothness and step-to-step accuracy. See **Fine Tuning** for more information on Waveform.

\*Limit moving duty cycle to 50%

**Note:** Low (ON) < 10 mH for 120 VAC;  
< 40 mH for 240 VAC.

### IMPORTANT

1. If any Resolution Switch (1, 2, or 3) is changed, **power must be cycled before changes will take effect.**
2. All other switches and potentiometers may be changed on-the-fly for immediate effect.

Drive Resolutions		Switch Settings		
STANDARD & -CW	LRES & LRES-CW	RES 1	RES 2	RES 3
5,000	200 cw/ccw	OFF	OFF	ON
10,000	400 cw/ccw	ON	OFF	ON
18,000	1000 cw/ccw	OFF	ON	ON
20,000	2000 cw/ccw	ON	ON	ON
<b>25,000</b>	200 Step & Dir	OFF	OFF	OFF
25,400	400 Step & Dir	ON	OFF	OFF
36,000	1000 Step & Dir	OFF	ON	OFF
50,000	2000 Step & Dir	ON	ON	OFF

# Mounting the NextStep

- Leave 3" above and below drives for air flow and wiring.
- Leave 0.1" between drives for easier mounting.
- Air supplied to the NextStep must be uncontaminated.

Typical Mounting Fasteners	
Cap Screw	Machine Screw
#10, #8, M4	#8, M4

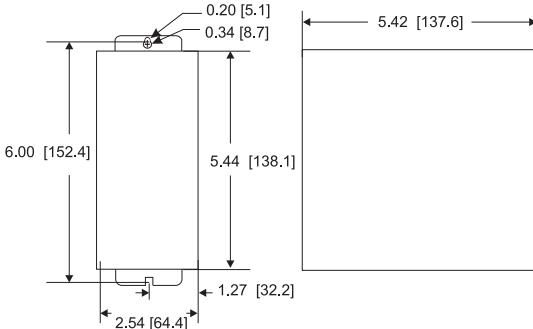

Mounting for Minimum Width Configuration (Standard)

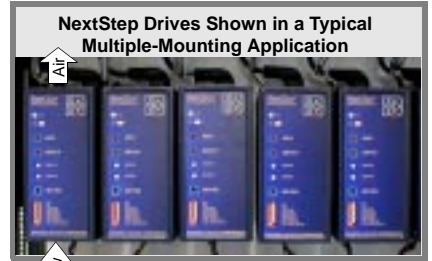

NextStep Drives Shown in a Typical Multiple-Mounting Application

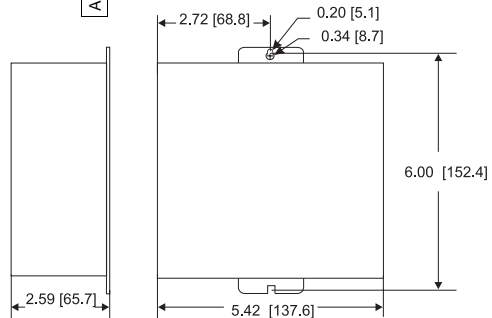

Mounting for Minimum Depth Configuration (NextStep-MD Option)

## ENVIRONMENTAL SPECIFICATIONS

Operating Ambient Temperature:  
Max. of 50°C (122°F) @ 6 amps

Not intended for use in humidity above 95% (non-condensing), or at altitudes greater than 2540 meters

Power Dissipation/Drive (watts)  
 $5 + 3.4I + .15I^2 = W$

## DIAGNOSTIC LEDs



## CONDITIONS INDICATED by LEDs

LED	Green	Yellow	Red
ON	Legal Power	Shutdown	Over Temperature
STEP	Incoming Steps, Direction CW	Incoming Steps, Direction CCW	---
BUS	---	Over Voltage = Solid Regen = Pulsed	Under Voltage
FLT	---	Interlock	Motor Short

# Fine-Tuning Your NextStep

**Adjust OFFSETS A and B** to optimize smoothness and step-to-step accuracy of each motor/drive system. To adjust Offsets:

1. Run the motor unloaded at the speed in the "Offset Test Speed" row below.
2. Alternately adjust Offset Pots A and B for best smoothness.

**Adjust Waveform** (once per motor-model) for better low speed smoothness as follows:

1. With the motor running at the speed indicated in the "Waveform Test Speed" row below, move the Waveform switch back and forth (from ON to OFF) to determine which setting produces the smoothest running condition.

MOTOR	S21	S22	S23	S32	S33	S42	P31	P32	P33	P41	P42	K42
<b>OFFSET TEST SPEED</b> in rps	4.46	3.91	3.57	2.98	2.76	2.11	3.54	3.49	3.36	2.85	2.75	3.14
<b>WAVEFORM TEST SPEED</b> in rps	1.12	.98	.89	.74	.69	.89	.88	.87	.84	.71	.69	.78
$J_{rotor}$ (Inertia) in kg-m <sup>2</sup>	1.17E-5	2.34E-5	3.51E-5	1.21E-4	1.88E-4	8.05E-4	1.4E-4	2.70E-4	4.0E-4	5.5E-4	1.09E-3	1.09E-3
<b>S-Series</b>	30.72	27.72	25.50	22.21	21.26	15.96	26.75	23.85	22.22	21.30	18.40	16.75
<b>S-Parallel</b>	26.81	23.81	21.59	18.30	17.36	11.95	22.84	19.94	18.31	17.39	14.49	12.84

**Calculate the Anti-Resonance (AR) Value** (See Drive Settings for "Unloaded Anti-Res")

To set the ANTI-RES dial and ANTI-RES switch, an anti-resonance value (**AR**) must be calculated (**AR=S-K**). Anti-Res settings for values of **AR** are shown in the table below. **S** is found in the table above for IDC motors. **K** must be calculated using the formula below left:

$$AR=S-K$$

$$K = \frac{\log\left(\frac{J_{rotor} + J_{load}}{J_{rotor}}\right)}{0.155}$$

$J_{rotor}$  is found in the table above.

$J_{load}$  is customer supplied.

**Calculating S for non-IDC motors:**

$$S = (12.987) \log \left[ \frac{9.3}{(V_b) \sqrt{(T_m)(J_{rotor})}} \right]$$

$V_b$  = break velocity or knee of speed-torque curve in rps.

$T_m$  = low speed torque of motor in N-m

**Set ANTI-RES dial and ANTI-RES switch (SW8)** according to chart below:

AR	ANTI-RES Dial	SW8 ON/OFF	AR	ANTI-RES Dial	SW8 ON/OFF	AR	ANTI-RES Dial	SW8 ON/OFF	AR	ANTI-RES Dial	SW8 ON/OFF
30	0	OFF	22	8	OFF	15	0	ON	7	8	ON
29	1	OFF	21	9	OFF	14	1	ON	6	9	ON
28	2	OFF	20	A	OFF	13	2	ON	5	A	ON
27	3	OFF	19	B	OFF	12	3	ON	4	B	ON
26	4	OFF	18	C	OFF	11	4	ON	3	C	ON
25	5	OFF	17	D	OFF	10	5	ON	2	D	ON
24	6	OFF	16	E	OFF	9	6	ON	1	E	ON
23	7	OFF		---	---	8	7	ON	0	F	ON