

*Operator's Manual*  
*Verdi™ V-2/V-5/V-6*  
*Diode-Pumped Lasers*

This document is copyrighted with all rights reserved. Under the copyright laws, this document may not be copied in whole or in part or reproduced in any other media without the express written permission of Coherent, Inc. Permitted copies must carry the same proprietary and copyright notices as were affixed to the original. This exception does not allow copies to be made for others, whether or not sold, but all the material purchased may be sold, given or loaned to another person. Under the law, copying includes translation into another language.

Coherent, the Coherent Logo, Verdi, and FAP-I are registered trademarks of Coherent, Inc.

This product is sold by Coherent pursuant to a limited sublicense under U.S. Patent No. Re 34,729. The rights which customers of Coherent receive through purchase of this product are restricted, and exclude any right to use the product in the telecommunications field.

Every effort has been made to ensure that the data given in this document is accurate. The information, figures, tables, specifications and schematics contained herein are subject to change without notice. Coherent makes no warranty or representation, either expressed or implied with respect to this document. In no event will Coherent be liable for any direct, indirect, special, incidental or consequential damages resulting from any defects in its documentation.

### **Technical Support**

#### **In the US:**

Should you experience any difficulties with your laser or need any technical information, please visit our web site [www.Coherent.com](http://www.Coherent.com). Additional support can be obtained by contacting our Technical Support Hotline at 800-367-7890 (408-764-4557 outside the U.S.) or E-mail [clg.tech.services@Coherent.com](mailto:clg.tech.services@Coherent.com). Telephone coverage is available Monday through Friday (except U.S. holidays and company shutdowns).

If you call outside our office hours, your call will be taken by our answering system and will be returned when the office reopens.

If there are technical difficulties with your laser that cannot be resolved by support mechanisms outlined above, please E-mail or telephone Coherent Technical Support with a description of the problem and the corrective steps attempted. When communicating with our Technical Support Department, via the web or telephone, the model and Laser Head serial number of your laser system will be required by the Support Engineer responding to your request.

#### **Outside the U.S.:**

If you are located outside the U.S. visit our web site for technical assistance or contact, by phone, our local Service Representative. Representative phone numbers and addresses can be found on the Coherent web site, [www.Coherent.com](http://www.Coherent.com).

Coherent provides telephone and web technical assistance as a service to its customers and assumes no liability thereby for any injury or damage that may occur contemporaneous with such services. These support services do not affect, under any circumstances, the terms of any warranty agreement between Coherent and the buyer. Operation of any Coherent laser with any of its interlocks defeated is always at the operator's own risk.

# TABLE OF CONTENTS

Preface .....	ix
U.S. Export Control Laws Compliance .....	ix
Symbols Used in This Manual and on the Laser System .....	x
<b>Section One: Laser Safety</b> .....	1-1
Optical Safety .....	1-1
Safety Features and Compliance to Government Requirements .....	1-2
Laser Classification.....	1-2
Protective Housing.....	1-3
Laser Radiation Emission Indicators .....	1-3
Beam Attenuator .....	1-3
Operating Controls.....	1-3
Location of Safety Labels .....	1-3
Electromagnetic Compatibility .....	1-3
<b>Section Two: Description and Specifications</b> .....	2-1
System Description .....	2-1
Laser Head .....	2-2
Power Supply .....	2-3
Servo Loops .....	2-3
Laser Diode Assembly.....	2-4
Specifications .....	2-5
<b>Section Three: Installation</b> .....	3-1
Receiving and Inspection.....	3-1
Installation Kit .....	3-1
Installing the Laser Head .....	3-1
Installing the Power Supply .....	3-5
Final Installation and Initial Turn-On Procedures .....	3-6
External Interlock .....	3-7
Dimensions .....	3-9
<b>Section Four: Operation</b> .....	4-1
Operation .....	4-1
Turn-on.....	4-2
Turn-on (Cold-Start) .....	4-2
LBO Optimization (Optional Step).....	4-3
Daily Turn-on (Warm-Start) .....	4-3
LBO Optimization (Optional Step).....	4-4
Turn-off.....	4-4
Turn-off (Daily Use) .....	4-4
Turn-off (Complete Shut-down).....	4-5
Controls, Indicators, and Features .....	4-6

Menu Displays .....	4-12
System Status Messages .....	4-12
Fault Handling .....	4-13
Low Power Warning .....	4-14

**Section Five: External Computer Control** ..... 5-1

How to Interface Verdi Lasers .....	5-1
RS-232 Command Language .....	5-1
Instruction Syntax for RS-232 Communication .....	5-1
ECHO Mode .....	5-2
PROMPT Mode .....	5-2
? .....	5-3
= or : .....	5-3
RS-232 Interface Connection .....	5-3
RS-232 Port Configuration .....	5-3
Setting The Baud Rate .....	5-3
Instruction Set .....	5-4

**Section Six: Maintenance and Service** ..... 6-1

Troubleshooting .....	6-1
FAP-I Replacement .....	6-22
Preliminary Steps and Data .....	6-22
FAP-I Handling Precautions .....	6-23
Fiber Cable Handling Precautions .....	6-24
FAP-I Removal .....	6-25
FAP-I Installation .....	6-27
Fiber Optic Cleaning .....	6-29
Equipment Needed .....	6-30
Fiberscope .....	6-30
Procedure .....	6-30
Drop and Drag Procedure .....	6-30
Cleanroom Swab Procedure .....	6-33
Alternative Cleaning Procedure .....	6-35
Examples of Good and Bad Fibers .....	6-37
LBO Temperature Optimization .....	6-40
Performing the Optimization .....	6-40
LBO Error Message .....	6-41
Fuse Replacement .....	6-41
Battery Replacement .....	6-42
Preliminary Steps and Data .....	6-42
Battery Removal and Installation .....	6-43
Battery Charge Circuit Verification .....	6-44
Verification of Successful Installation .....	6-45
Cleaning the Air Filter .....	6-45
Criteria for Cleaning .....	6-46

<b>Section Seven: General Operating Principles</b> .....	7-1
Laser Head .....	7-1
Gain Medium .....	7-2
Second Harmonic Generator .....	7-2
Temperature Servos .....	7-3
Output Optics .....	7-4
Power Monitor .....	7-4
Shutter .....	7-4
Heat Sinking .....	7-5
Umbilical .....	7-5
Power Supply .....	7-6
Laser Diode .....	7-6
Battery Backup .....	7-8
Cooling Issues .....	7-8
<b>Packing Procedure</b> .....	A-1
<b>Parts List</b> .....	B-1
<b>Accessories</b> .....	C-1
Power Meters and Sensors .....	C-1
Recommendation .....	C-1
<b>Warranty</b> .....	D-1
Responsibilities of the Buyer .....	D-1
Limitations of Warranty .....	D-1
<b>Glossary</b> .....	Glossary-1
<b>Index</b> .....	Index-1

## LIST OF ILLUSTRATIONS

1-1.	Safety Features and Labels .....	1-4
2-1.	Verdi V-2/V-5/V-6 Laser System .....	2-1
2-2.	Laser Head Optical Schematic.....	2-3
3-1.	Installation Kit .....	3-2
3-2.	Riser/Heatsink.....	3-4
3-3.	Laser Head Base – Protective Cover Installed.....	3-4
3-4.	Laser Head Base – Protective Cover Removed.....	3-5
3-5.	External Interlock .....	3-7
3-6.	Interconnect Diagram .....	3-8
3-7.	Laser Head Dimensions .....	3-9
3-8.	Power Supply Dimensions.....	3-10
4-1.	Laser Head Features.....	4-6
4-2.	Power Supply Front Panel Controls and Indicators.....	4-8
4-3.	Power Supply Rear Panel Controls and Indicators.....	4-10
4-4.	Menus.....	4-12
5-1.	RS-232 Pin Configuration .....	5-4
6-1.	Location of FAP-I Assemblies and Fiber Looping.....	6-23
6-2.	Fiber Optic Covers and FAP-I Anode/Cathode Shorting Clip.....	6-24
6-3.	FAP-I Assembly Interface.....	6-26
6-4.	FAP-I Fiber Optic Connector.....	6-27
6-5.	Preparation of the Replacement FAP-I Assembly .....	6-28
6-6.	Fiberscope with 20X Eyepiece and SMA Adapter .....	6-31
6-7.	Methanol Drop on Lens Tissue.....	6-31
6-8.	Placement of the Fiber Optic Against the Lens Tissue.....	6-32
6-9.	Movement of Fiber Optic Against Lens Tissue.....	6-32
6-10.	Methanol Residue .....	6-33
6-11.	Methanol Drop.....	6-34
6-12.	Placement and Movement of the Swab Against the Fiber Optic Surface.....	6-34
6-13.	Folded Lens Tissue (Width Wise).....	6-35
6-14.	Folded Lens Tissue (Lengthwise).....	6-35
6-15.	Hemostat Attached to Properly Folded Lens Tissue.....	6-36
6-16.	Placement and Movement of the Folded Tissue Against the Fiber Optic Surface .....	6-37
6-17.	Good Fiber .....	6-38
6-18.	Bad or Questionable Fibers.....	6-38
6-19.	Guidelines for Fiber Optic Inspection .....	6-39
6-20.	Power Supply Backup Battery .....	6-43
6-21.	Location of Battery Charge Circuit Resistor, R8.....	6-45

A-1.	Packed Verdi V-2/V-5/V-6 Laser Shipping Crate .....	A-2
A-2.	Top Foam for Verdi V-2/V-5/V-6 Laser Shipping Crate .....	A-3
A-3.	Proper Packing of System Umbilical.....	A-3
A-4.	Location of Packed Verdi V-2/V-5/V-6 Laser Maintenance Kit .....	A-4

## LIST OF TABLES

2-1.	Specifications.....	2-5
3-3.	Laser System Dimensions.....	3-7
3-1.	Utility Requirements.....	3-8
3-2.	Environmental Requirements .....	3-9
4-1.	Operating States.....	4-1
4-2.	Laser Head Features.....	4-7
4-3.	Power Supply Front Panel Controls and Indicators.....	4-9
4-4.	Power Supply Rear Panel Controls and Indicators.....	4-11
4-5.	Submenus.....	4-14
5-1.	Response from Laser after Receiving Instruction.....	5-2
5-2.	RS-232 Port Description.....	5-3
5-3.	RS-232 Commands.....	5-5
5-4.	RS-232 Queries.....	5-6
6-1.	Troubleshooting/Fault Messages .....	6-1
6-2.	Battery Charge Circuit Voltages .....	6-44
A-1.	Verdi V-2/V-5/V-6 Laser Shipping Crate Contents.....	A-1

## LIST OF CHARTS

1.	Laser Does Not Start (No Light Output).....	6-4
2.	Laser Shuts Down (No Light Output).....	6-6
3.	Laser Output Unstable .....	6-8
4.	AC ON Indicator Does Not Light.....	6-10
5.	Head Laser Emission Lamp Fault.....	6-12
6.	External Interlock Fault .....	6-13
7.	PS Interlock Fault .....	6-14
8.	LBO Temperature Fault; Vanadate Temperature Fault; Etalon Temperature Fault; Diode 1 Temperature Fault .....	6-15
9.	Baseplate Temperature Fault.....	6-16
10.	Diode Heat Sink Temperature Fault .....	6-17
11.	Diode Over Current Fault; Over Current Fault; 10% Current Increase (No Fault).....	6-18
12.	Diode Under Voltage Fault; Diode Over Voltage Fault; Diode EEPROM Fault; LBO Not Locked at Set Temperature; Laser Head EEPROM Fault; Power Supply EEPROM Fault; Power Supply-Head Mismatch Fault; Shutter State Mismatch; Head-Diode Mismatch Fault.....	6-20
13.	Battery Requires Service .....	6-21



## Preface

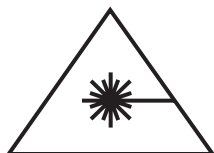
This manual contains user information for the Verdi™ V-2/V-5/V-6 Diode-Pumped Lasers.



---

**Read this manual carefully before operating the laser for the first time. Special attention should be given to the material in Section One: Laser Safety, which describes the safety features built into the laser.**

---



---

**Use of controls or adjustments or performance of procedures other than those specified in this manual may result in hazardous radiation exposure.**

---



---

**Use of the system in a manner other than that described herein may impair the protection provided by the system.**

---

## U.S. Export Control Laws Compliance

It is the policy of Coherent to comply strictly with U.S. export control laws.

Export and re-export of lasers manufactured by Coherent are subject to U.S. Export Administration Regulations, which are administered by the Commerce Department. In addition, shipments of certain components are regulated by the State Department under the International Traffic in Arms Regulations.

The applicable restrictions vary depending on the specific product involved and its destination. In some cases, U.S. law requires that U.S. Government approval be obtained prior to resale, export or re-export of certain articles. When there is uncertainty about the obligations imposed by U.S. law, clarification should be obtained from Coherent or an appropriate U.S. Government agency.

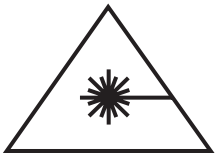
## **Symbols Used in This Manual and on the Laser System**



---

**This symbol is intended to alert the operator to the presence of important operating and maintenance instructions.**

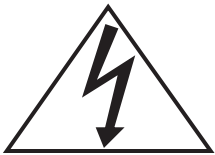
---



---

**This symbol is intended to alert the operator to the danger of exposure to hazardous visible and invisible laser radiation.**

---



---

**This symbol is intended to alert the operator to the presence of dangerous voltages within the product enclosure that may be of sufficient magnitude to constitute a risk of electric shock.**

---



---

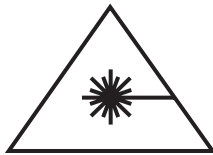
**This symbol is intended to alert the operator to the danger of Electro-Static Discharge (ESD) susceptibility.**

---

## SECTION ONE: LASER SAFETY

### Optical Safety

Laser light, because of its special properties, poses safety hazards not associated with light from conventional sources. The safe use of lasers requires that all laser users, and everyone near the laser system, are aware of the dangers involved. The safe use of the laser depends upon the user being familiar with the instrument and the properties of coherent, intense beams of light.



---

**Direct eye contact with the output beam from the laser will cause serious damage and possible blindness.**

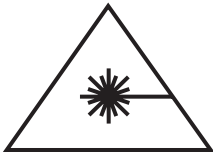
---

The greatest concern when using a laser is eye safety. In addition to the main beam, there are often many smaller beams present at various angles near the laser system. These beams are formed by specular reflections of the main beam at polished surfaces such as lenses or beamsplitters. While weaker than the main beam, such beams may still be sufficiently intense to cause eye damage.

Laser beams are powerful enough to burn skin, clothing or paint. They can ignite volatile substances such as alcohol, gasoline, ether and other solvents, and can damage light-sensitive elements in video cameras, photomultipliers and photodiodes. The laser beam can ignite substances in its path, even at some distance. The beam may also cause damage if contacted indirectly from reflective surfaces. For these reasons, and others, the user is advised to follow the precautions below.

1. Observe all safety precautions in the preinstallation and operator's manual.
2. Extreme caution should be exercised when using solvents in the area of the laser.
3. Limit access to the laser to qualified users who are familiar with laser safety practices and who are aware of the dangers involved.
4. Never look directly into the laser light source or at scattered laser light from any reflective surface. Never sight down the beam into the source.
5. Maintain experimental setups at low heights to prevent inadvertent beam-eye encounter at eye level.

6. As a precaution against accidental exposure to the output beam or its reflection, those using the system should wear laser safety glasses as required by the wavelength being generated.
7. Avoid direct exposure to the laser light. The intensity of the beam can easily cause flesh burns or ignite clothing.
8. Use the laser in an enclosed room. Laser light will remain collimated over long distances and therefore presents a potential hazard if not confined.
9. Post warning signs in the area of the laser beam to alert those present.
10. Advise all those using the laser of these precautions. It is good practice to operate the laser in a room with controlled and restricted access.



---

**Laser safety glasses can present a hazard as well as a benefit; while they protect the eye from potentially damaging exposure, they block light at the laser wavelengths, which prevents the operator from seeing the beam. Therefore, use extreme caution even when using safety glasses.**

---

## **Safety Features and Compliance to Government Requirements**

The following features are incorporated into the instrument to conform to several government requirements. The applicable United States Government requirements are contained in 21 CFR, subchapter J, part II administered by the Center for Devices and Radiological Health (CDRH). The European Community requirements for product safety are specified in the Low Voltage Directive (LVD) (published in 73/23/EEC and amended in 93/68/EEC). The Low Voltage Directive requires that lasers comply with the standard EN 61010-1 "Safety Requirements For Electrical Equipment For Measurement, Control and Laboratory Use" and EN60825-1 "Radiation Safety of Laser Products". Compliance of this laser with the (LVD) requirements is certified by the CE mark.

## **Laser Classification**

The governmental standards and requirements specify that the laser must be classified according to the output power or energy and the laser wavelength. The Verdi V-2/V-5/V-6 Lasers are classified as Class IV based on 21 CFR, subchapter J, part II, section 1040-10 (d). According to the European Community standards, Verdi V-2/V-5/V-6 lasers are classified as Class 4 based on EN 60825-1, clause 9. In this manual, the classification will be referred to as Class 4.

**Protective Housing**

The laser head is enclosed in a protective housing that prevents human access to radiation in excess of the limits of Class I radiation as specified in the Federal Register, July 31, 1975, Part II, Section 1040.10 (f) (1) and Table 1-A/EN 60825-1, clause 4.2 except for the output beam, which is Class IV.

**Laser Radiation Emission Indicators**

The appropriately labeled lights on both the power supply and the laser head illuminate approximately 30 seconds before laser emission can occur. Amber lights are used so that they will be seen when the proper type of safety glasses are used [CFR 1040.10(f)(5)/EN 60825-1, clause 4.6].

**Beam Attenuator**

A beam attenuator, or shutter, prevents contact with laser radiation without the need to switch off the laser [CFR 1040.10 (f)(6)/EN 60825-1, clause 4.7].

**Operating Controls**

The laser controls are positioned so that the operator is not exposed to laser emission while manipulating the controls [CFR 1040.10(f)(7)/EN 60825-1, clause 4.8].

**Location of Safety Labels**

Refer to Figure 1-1 for a description and location of all safety labels. These include warning labels indicating removable or displaceable protective housings, apertures through which laser radiation is emitted and labels of certification and identification [CFR 1040.10(g), CFR 1040.2, and CFR 1010.3/ EN60825-1, Clause 5]].

**Electromagnetic Compatibility**

The European requirements for Electromagnetic Compliance (EMC) are specified in the EMC Directive (published in 89/336/EEC).

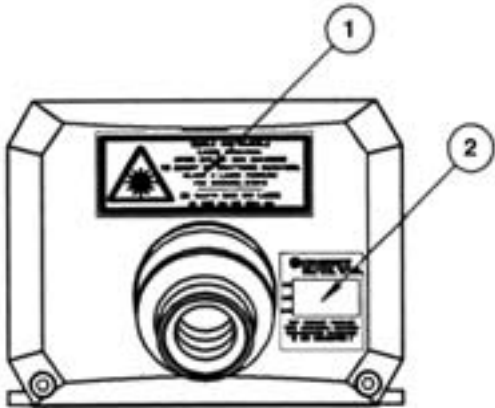
Conformance (EMC) is achieved through compliance with the harmonized standards EN55011 (1991) for emission and EN50082-1 (1992) for immunity.

The laser meets the emission requirements for Class B, group 1 as specified in EN55011 (1991).

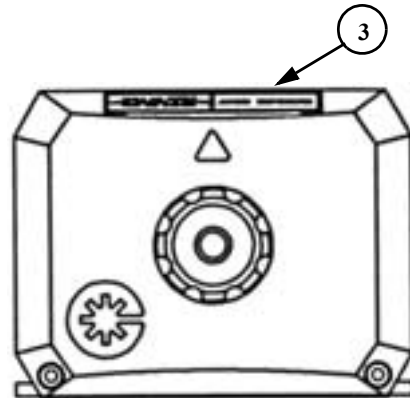
Compliance of this laser with the (EMC) requirements is certified by the CE mark.

LASER HEAD

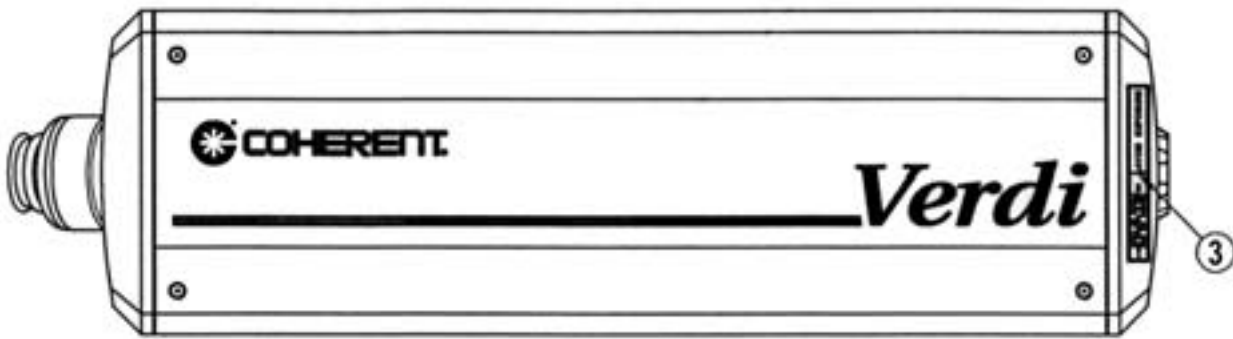
REAR VIEW



FRONT VIEW



TOP VIEW



POWER SUPPLY

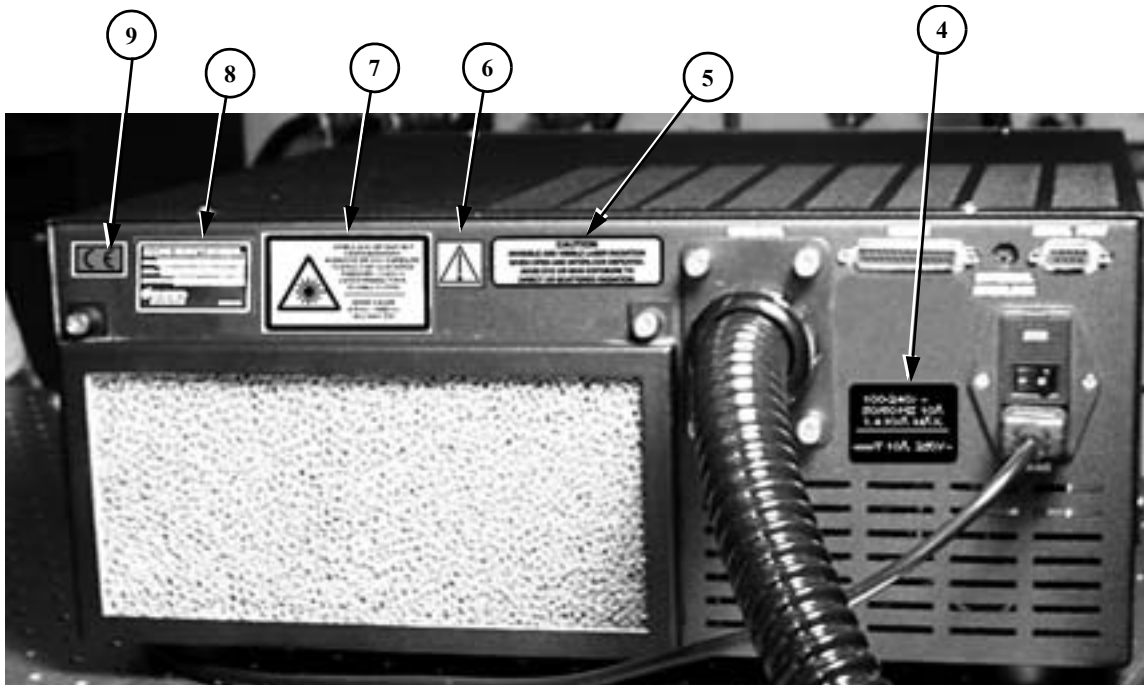
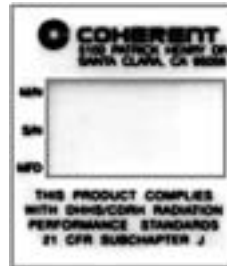


Figure 1-1. Safety Features and Labels (Sheet 1 of 3)



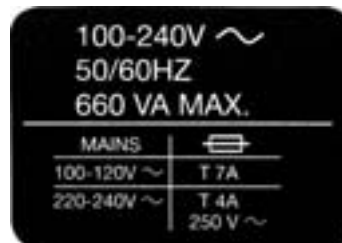
1.



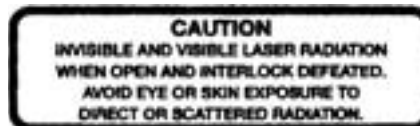
2.



3.



4.



5.

Figure 1-1. Safety Features and Labels (Sheet 2 of 3)



6.



7.



8.



9.

*Figure 1-1. Safety Features and Labels (Sheet 3 of 3)*



## SECTION TWO: DESCRIPTION AND SPECIFICATIONS

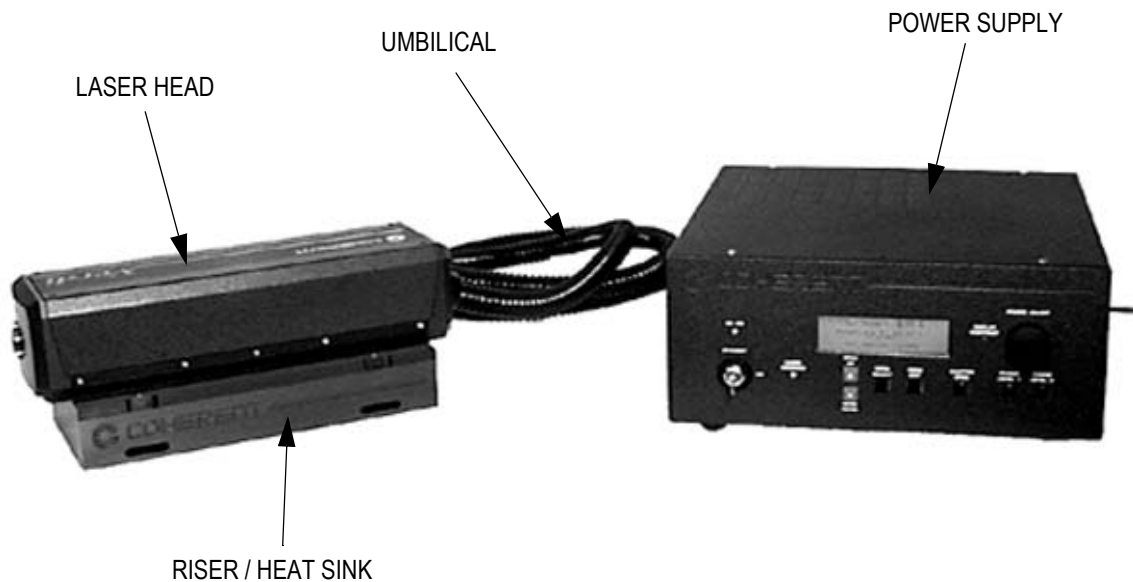
### System Description

The Verdi V-2/V-5/V-6 laser system (Figure 2-1) is a compact solid-state diode-pumped, frequency-doubled Nd:Vanadate (Nd:YVO<sub>4</sub>) laser that provides single-frequency green (532 nm) output at power levels greater than 2 Watts/5 Watts/6 Watts. Single frequency operation results in lower noise in the green output.

The Verdi V-2/V-5/V-6 laser consists of the laser head and power supply connected by an umbilical. The umbilical contains a fiber optic cable to transmit light from the diode bar in the power supply to the laser head. It also houses electrical cables that provide control and monitoring signals between the laser head and power supply.

The Verdi V-2/V-5/V-6 laser consists of the laser head and power supply connected by an umbilical. The umbilical contains a fiber optic cable to transmit light from the diode bar in the power supply to the laser head. It also houses electrical cables that provide control and monitoring signals between the laser head and power supply.

The laser head is shown mounted on a riser/heat sink. The riser/heat sink can be the passive version or the water cooled version depending on the operating environment.



*Figure 2-1. Verdi V-2/V-5/V-6 Laser System*



---

**The passive riser/heat sink alone does not possess sufficient mass to maintain the laser head base below 55°C and accordingly should be mounted on a thermally conductive surface as described in the installation section.**

---

## Laser Head

The major optical elements are in a hermetically sealed head and includes:

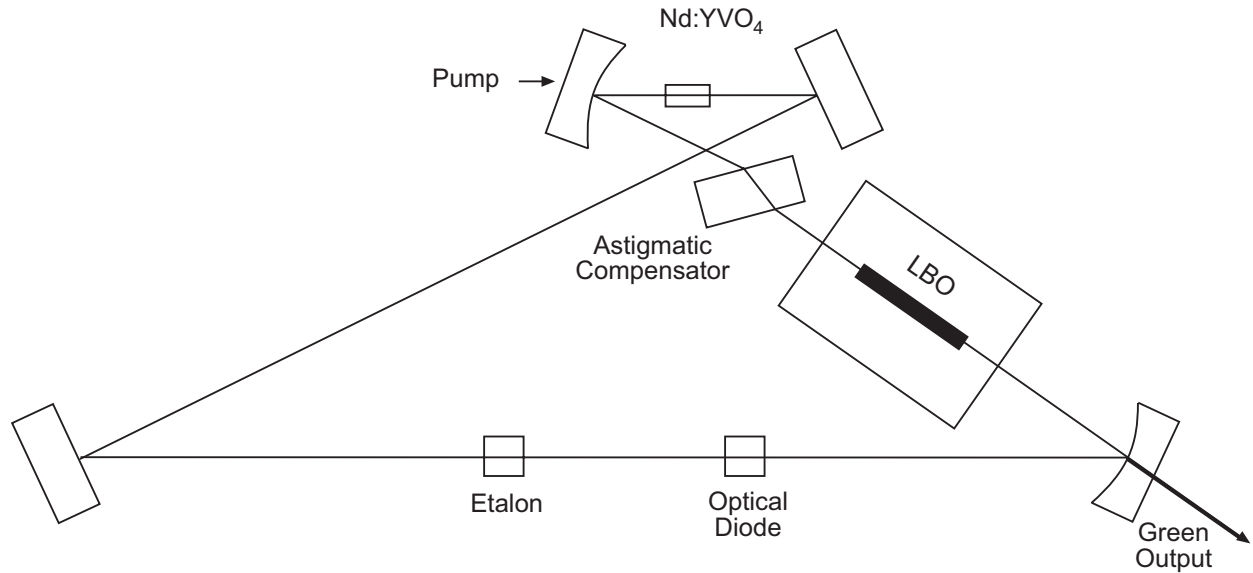
- Vanadate as the gain medium
- LBO as the frequency doubling crystal
- An etalon as the single-frequency optic
- Optical diode
- Astigmatic compensator and three cavity mirrors

All optical components are mounted on proprietary Super Invar for strength and stability.

The temperature of the Vanadate and etalon are controlled by thermo-electric coolers (TECs), which are capable of heating or cooling the optical element. The temperature of the lithium triborate (doubling generator, or LBO), is controlled by a resistive heater. Accumulated heat in the laser head is dissipated by an optional riser/heat sink mounted on the laser head baseplate. Baseplate temperature is monitored by a CPU in the power supply, which will shut the system down if the laser head temperature reaches 55°C.

The laser head utilizes a Neodymium Vanadate (Nd:YVO<sub>4</sub>) crystal with the pump power provided by fiber delivery.

The nonlinear medium is a Type I, non-critically phase matched LBO crystal held at approximately 150°C. Unidirectional operation is achieved using an optical diode. Since the laser is a unidirectional, homogeneously broadened system, it tends to naturally run single frequency, with the etalon reinforcing this behavior.



**Figure 2-2. Laser Head Optical Schematic**

## Power Supply

The main functions of the power supply include:

- Supplying DC power for the laser diode system that pumps the gain medium in the laser head
- Controlling six servo loops
- Cooling for the laser diode assemblies
- Controlling and monitoring the laser output
- Storing data
- Providing a user interface.

## Servo Loops

The CPU controlled servo loops are briefly described below. See “Temperature Servos” on page 7-3 for additional information.

Light loop – A photodiode in the laser head monitors the laser output. The CPU controls the output power from the Verdi laser based on the photodiode and in conjunction with the requested power from the power supply front panel. The CPU achieves this control by adjusting the diode pump power to the Vanadate.

- LBO temperature – The LBO doubling crystal is held at approximately 148°C by a resistive heater. To prevent rapid change of temperature that may cause LBO crystal damage during warm-up, the CPU regulates a slow ramp-up to operating temperature. This typically lasts fewer than 30 minutes.

In case of loss of AC power (due to a power failure or inadvertently turning off the rear panel power switch), the laser is equipped with a battery powered, CPU-controlled, cool-down feature. This feature lowers the LBO temperature gradually to room temperature.

- Diode temperature – Diode operating temperature is held constant by the TEC's. Excess heat is dissipated by forced air cooling through heat sinks. The diode heat sinks are located within the power supply.
- Vanadate and etalon temperature – These optical components are maintained at preset levels by TECs.

### **Laser Diode Assembly**

One laser diode assembly is located in the power supply. This assembly is controlled and monitored by the CPU. The FAP-IT<sup>™</sup> (fiber array package- integrated) assembly houses a diode bar and a TEC.

See "Laser Diode" on page 7-6 for additional information on the laser diode assemblies.

**Specifications**

Specifications for the Verdi V-2/V-5/V-6 lasers are listed in Table 2-1.

**Table 2-1. Specifications**

PARAMETER	SPECIFICATION
Output Power	2, 5, or 6 W
Wavelength	532 nm
Beam Diameter <sup>[1]</sup>	2.25 mm $\pm$ 10%
Beam Divergence <sup>[2]</sup>	< 0.5 mrad
M <sup>2</sup>	< 1.1
Power Stability <sup>[3]</sup>	$\pm$ 1%
Noise <sup>[4]</sup>	< 0.02% rms
Polarization	> 100:1, vertical, linear
Linewidth <sup>[5]</sup>	< 5 MHz rms
Pointing Stability <sup>[6]</sup>	< 2 $\mu$ rad/ $^{\circ}$ C
<p>All specifications are subject to change without notice.            [1] <math>1/e^2</math> at exit port.            [2] Full-angle divergence.            [3] Measured over 2 hours after a 15 minute warm-up.            [4] Measured from 10 Hz to 1 GHz.            [5] Measured over 50 msec with a thermally stabilized reference etalon.            [6] 25<math>^{\circ}</math>C to 35<math>^{\circ}</math>C temperature change.</p>	



## SECTION THREE: INSTALLATION

### **Receiving and Inspection**

Inspect shipping containers for signs of rough handling or damage. Indicate any such signs on the bill of lading. Report any damage immediately to the shipping carrier, and to Coherent Order Administration Department (800-438-6323) or to an authorized Coherent representative.



---

**Retain shipping containers. The containers will be required if the system is returned to the factory for service. The containers may also be needed to support a shipping damage claim.**

---

Coherent recommends that three people unpack and transport the Verdi V-2/V-5/V-6. The power supply weighs 70 pounds and should be lifted by two people while the laser head, which weighs 22.2 pounds, can be lifted by the third person. The laser head and power supply are connected by the umbilical.

### **Installation Kit**

The installation kit contains the necessary hardware for Verdi installation. See Figure 3-1 for details.

### **Installing the Laser Head**

The laser head is shipped with either a passive or a water-cooled riser/heat sink. This riser/heat sink maintains the Verdi output beam at a suitable height for pumping a laser such as the Coherent Mira.

A passive riser/heat sink when mounted on a thermally conductive surface (such as an optical table) provides sufficient heat dissipation for the laser head under normal ambient conditions. The temperature of the laser head baseplate is monitored by the Verdi power supply and can be displayed on the power supply front panel. Power dissipation through the baseplate is typically 20 to 25 Watts (30 Watts maximum). The Verdi will shut down if the baseplate temperature exceeds 55°C.

An optional water-cooled riser/heat sink is available for use with a chiller.

The laser head is shipped with a protective plastic plate installed over the baseplate. Leave the plastic plate in place until laser head is ready for installation.



- |  |  |
|--|--|
| 1. Riser/heat sink installation hardware | 6. Interlock-disassembled  |
| 2. Operator's manual                     | 7. Fuses and instructions  |
| 3. AC power cord                         | 8. FAP-I installation hardware, including shorting clips, end caps, etc. |
| 4. Power supply key                      | 9. Laser head/heat sink mounting hardware                                |
| 5. Installation kit case                 | 10. Dowel pins – laser head/heat sink                                    |

**Figure 3-1. Installation Kit**

1. Remove the packing material from the riser/heat sink (Figure 3-2).
2. Insert two dowel pins (Figure 3-1 , item 12) into the riser/heat sink dowel holes (Figure 3-2, item 1), ball-end up.





---

**Avoid damage to the laser head baseplate, which is milled to a flatness of  $\pm 0.1$  mm. This tolerance provides maximum thermal conduction between the baseplate and the mounting surface.**

---



---

**Keep the umbilical as straight as possible while avoiding rotating the laser head with respect to the power supply.**

---



---

**Do not apply thermal compound or any other material on the laser head baseplate or on the riser/heat sink.**

---

3. Remove the laser head and power supply from the shipping crate. Place the laser head on its side and on a protected surface to avoid scratching the cover as shown on Figure 3-3. Remove the three screws (Figure 3-3, item 2) securing the protective plastic cover (item 4) to the laser head baseplate. Any scratches, damage, or contamination of the baseplate will reduce the thermal conduction between the baseplate and the mounting surface.
4. Refer to Figure 3-4 for the laser head dowel pin positions. Carefully place the laser head over the riser/heat sink and onto the dowel pins.

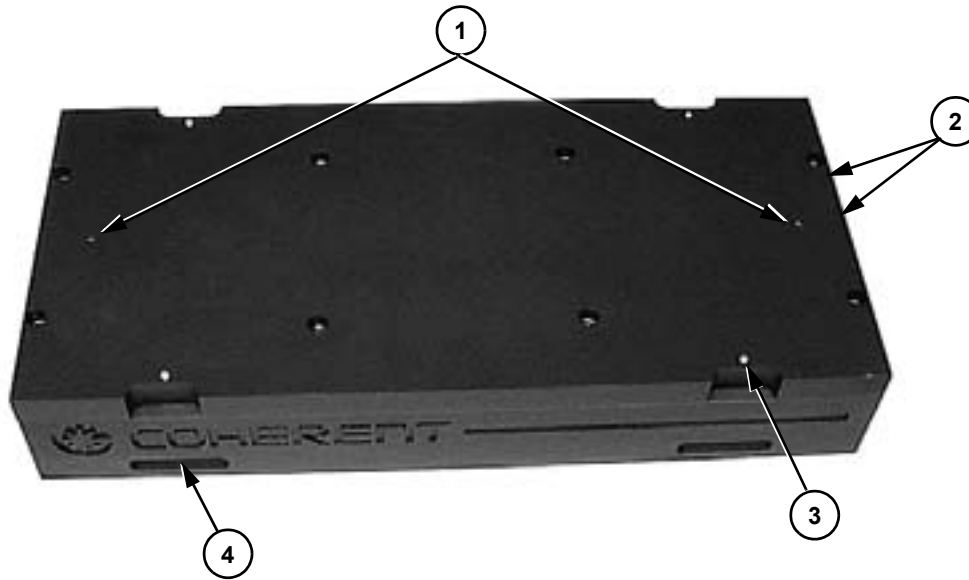


---

**Do not use excessive force when clamping the Verdi to the riser/heat sink.**

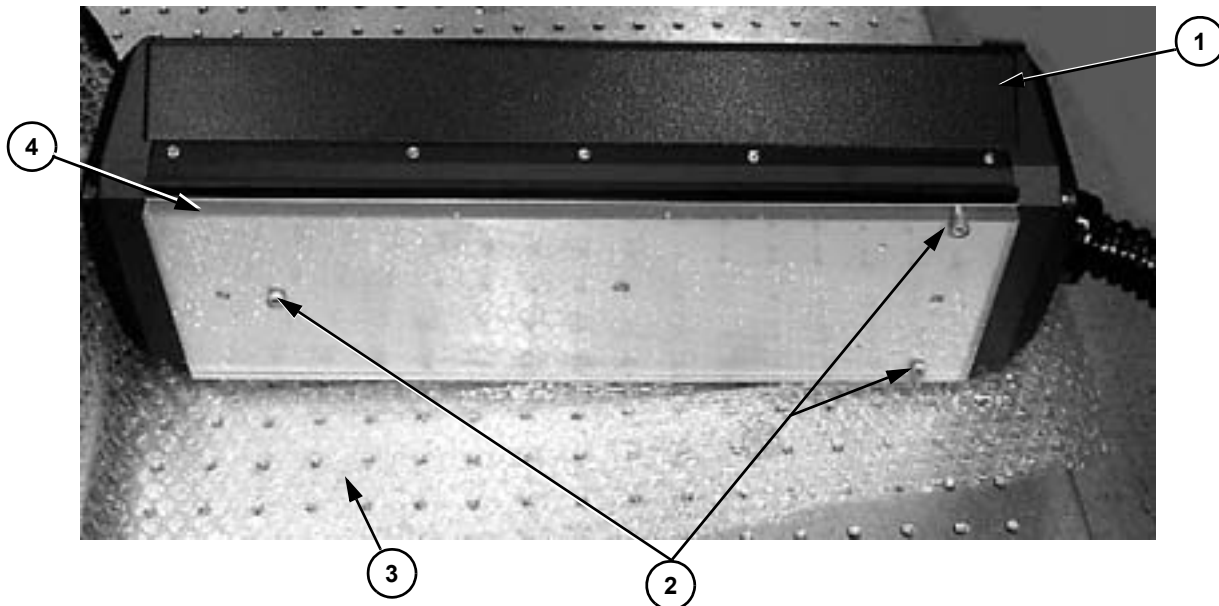
---

5. Use four laser head clamps (Figure 3-1 item 9) to secure the laser head to the riser/heat sink as shown in Figure 4-1 on page 4-6. Tighten the 4 clamps firmly using an Allen head wrench.
6. Proceed to the paragraph titled, "Installing the Power Supply". The riser/heat sink clamps and chiller connection will be installed during the final installation procedures.



- 1. Dowel holes (2)
- 2. Cooling water inlet and outlet (if included)
- 3. Laser head clamp screw holes (4)
- 4. Optical table clamp mounts (4)

**Figure 3-2. Riser/Heatsink**



- 1. Laser head
- 2. Protective plastic cover retaining screws (3)
- 3. Protective material
- 4. Protective plastic cover

**Figure 3-3. Laser Head Base – Protective Cover Installed**



DOWEL PIN HOLES

*Figure 3-4. Laser Head Base – Protective Cover Removed*

## **Installing the Power Supply**

1. Move the power supply to an accessible-friendly location, preferably away from heat producing sources. Ensure the cooling intake and exhaust (rear, top, and left side) are not blocked or obstructed.

If storing the power supply in a 19 in. (48 cm) equipment rack, allow a minimum horizontal clearance of 17.937 in. (45.56 cm) for the front panel of the power supply.




---

**The system will not operate with the interlock open. For additional information on the interlock, including the connection of an external interlock circuit, refer to the paragraph titled, “External Interlock”.**

---

2. Connect the interlock connector (Figure 3-1, item 6) on the rear of the power supply in the location shown in Figure 4-3 on page 4-10.

The interlock connector may be located in the installation kit or may be attached to the umbilical.

3. Connect the AC power cord on the rear of the power supply in the location shown in Figure 4-3 on page 4-10. Do not connect the AC power cord at this time.

Each customer must inspect the power cord and install the proper connector if necessary. The connector should be installed in a properly grounded outlet with a maximum of

10 Ampere service @ 110 V and 11 Ampere service @ 220 V for proper overcurrent and earth fault protection.

4. Proceed to the paragraph titled, "Final Installation and Initial Turn-On Procedures".

## **Final Installation and Initial Turn-On Procedures**

After installing the laser head and power supply in accordance with paragraphs titled, "Installing the Laser Head" and "Installing the Power Supply", complete the installation as follows:

1. Position the power supply and laser head in the operating position with the umbilical as straight as possible. Ensure that the umbilical has a bend radius of 5 inches or greater. A distance of 6 to 24 inches is recommended between the Verdi output and any laser being pumped.



---

**Excessively tight umbilical bends (less than a 5 inch radius) can cause permanent damage to the optical fiber.**

---

2. If a water-cooled system is used, position the chiller in the operating position. Fill and prepare the chiller in accordance with the chiller user's manual.
3. Cut the user-supplied cooling water lines to the appropriate lengths and use the water line hardware (Figure 3-1, item 9) to connect the riser/heat sink to the chiller (Figure 3-6). Apply teflon tape to the hardware threads and install the washers from the installation kit over the threads when connecting the stainless steel ferrule to the riser/heat sink. Check the system for leaks.
4. If a passive riser/heat sink will be used, ensure the riser/heat sink is mounted on a thermally conductive surface (such as an optical table) that provides sufficient heat dissipation to maintain the laser head baseplate below 55°C, preferably below 40°C.
5. Use four riser/heat sink clamps (Figure 3-1, item 1) to secure the system to the optical table as shown in Figure 4-1 on page 4-6. Tighten the two front clamps firmly using an Allen head wrench. Tighten the two rear clamps finger tight only.
6. Connect power supply to facility power. Ensure all packing materials have been removed.
7. Perform the procedure in paragraph titled, "Turn-on (Cold-Start)" on page 4-2.

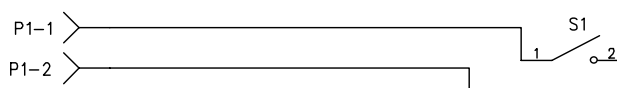
## External Interlock

The system will not operate with the interlock open. An interlock connector is located on the power supply rear panel. The interlock status is monitored by the CPU. If the interlock is open, the message, “External Interlock Fault” will be displayed on the power supply front panel.

An external interlock circuit can be connected to the laser system and wired to a door switch to provide additional operating safety. When the door is opened, the laser will shut down. Press MENU EXIT key to clear the fault and continue operation.

To incorporate an external safety interlock circuit into the laser system, perform the following steps:

1. Turn off the laser system. Locate and remove the Interlock connector from the back of the Verdi power supply. This type of connector is called a “three pin mini-DIN”.
2. Slide the plastic cover off of the connector. Locate the two pins that have a wire soldered between them. These are pins 1 and 2. Remove the shorting wire and solder your interlock wires to these two pins. Make sure the wires have adequate strain relief.
3. Solder the other ends of the wires to an interlock switch. You can use many types of switches. The switch must be of a type that has its contacts **closed** when it is safe to operate the laser and open when it is not safe.
4. Figure 3-5 shows the wiring diagram for the switch. One wire runs from pin 1 of the connector to the normally open contact of the switch. The other wire runs from pin 2 to the common terminal of the switch. The switch is shown in the open position. This is the condition in which you do not want the laser beam to operate.



**Figure 3-5. External Interlock**

5. The interlock circuit in Verdi operates from a +/-12 VDC circuit. Its current is limited to around 1 mA. For these ratings, a “dry-circuit” type switch will give the most reliable operation.

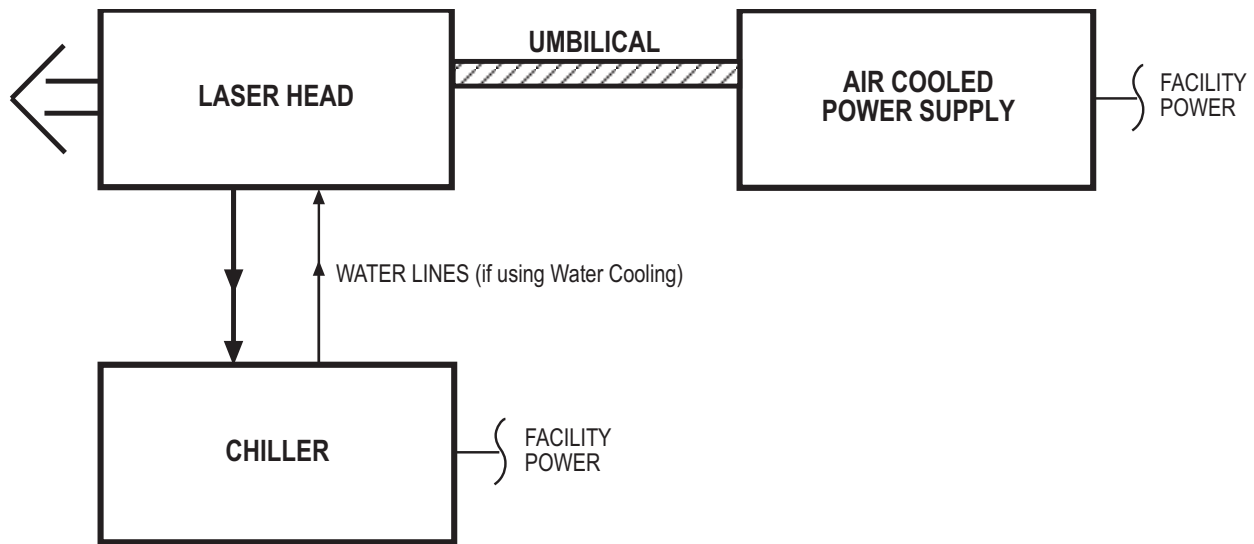


Figure 3-6. Interconnect Diagram

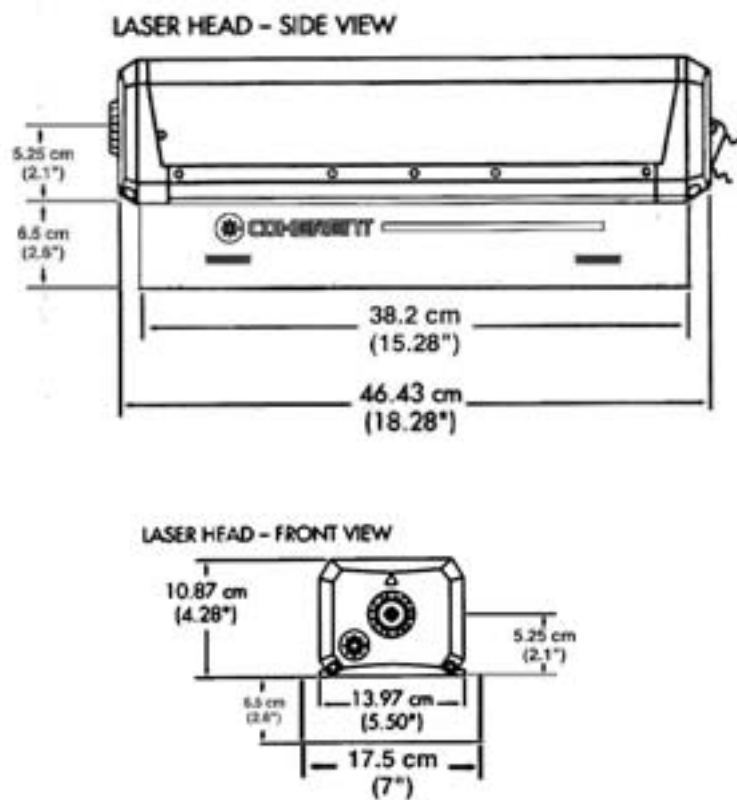
Table 3-1. Utility Requirements

PARAMETER	REQUIREMENT
Power Requirements	100 to 240 VAC <sup>[1][2]</sup>
Maximum Current	6.5 Amps @ 100 VAC 7 Amps @ 220 VAC
Cooling: Laser head: Power supply:	Riser/heat sink <sup>[3]</sup> Air-cooled with ambient air
<p>Note: All specifications and requirements are subject to change without notice.</p> <p>[1] The power supply is autoranging and will accommodate the full range of input voltages without hardware changes.</p> <p>[2] The electrical service should have a main power disconnect switch located in close proximity to the laser. The main power disconnect switch shall be clearly marked as the disconnecting device for the laser, and shall be within easy reach of the operator.</p> <p>[3] The passive riser/heat sink must be mounted on a conductive surface capable of maintaining the laser head base-plate at less than 55°C. An optional riser/heat sink and chiller or chill plate can also be used. Refer to the paragraph titled, Installing the Laser Head, for additional information on removing waste heat from the laser head.</p>	

**Table 3-2. Environmental Requirements**

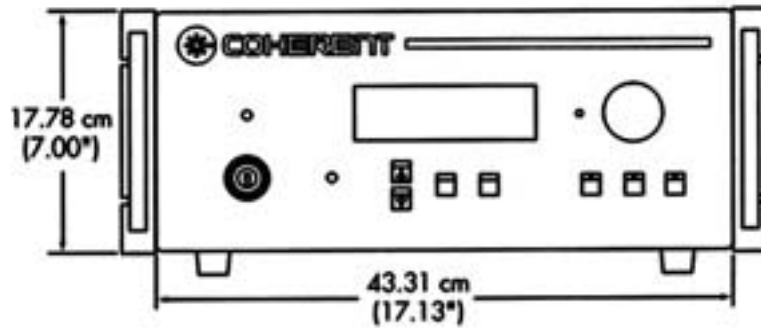
PARAMETER	REQUIREMENT
Operating temperature	15 to 35°C (59 to 95°F)
Relative humidity	5 to 95% (non condensing)
Altitude	Sea level to 10,000 feet

## Dimensions



**Figure 3-7. Laser Head Dimensions**

POWER SUPPLY - FRONT VIEW



POWER SUPPLY - SIDE VIEW

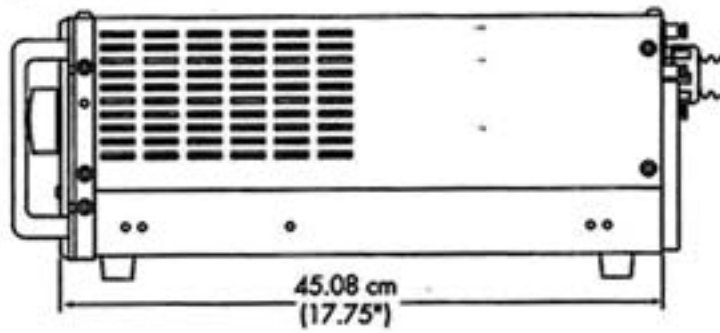
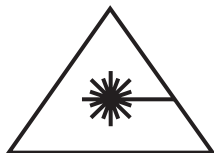


Figure 3-8. Power Supply Dimensions



## SECTION FOUR: OPERATION

### Operation




---

**Wear laser safety glasses to protect against the radiation generated from the laser. It is assumed that the operator has read Section One: Laser Safety, and is familiar with laser safety practices and the dangers involved. Ensure all personnel in the area are wearing laser safety glasses.**

---

*Table 4-1. Operating States*

STATE	SWITCH POSITION	STATUS
OFF	<ul style="list-style-type: none"> <li>Power Switch (rear panel): OFF.</li> <li>All other switches: Any position.</li> </ul>	All functions off (except LBO CPU until cool-down is complete).
STANDBY	<ul style="list-style-type: none"> <li>Power Switch (rear panel): ON.</li> <li>Keyswitch: STANDBY.</li> </ul>	Laser diode off. Vanadate temperature servo on. LBO temperature servo on. Etalon temperature servo on.
ON	<ul style="list-style-type: none"> <li>Power Switch (rear panel): ON.</li> <li>Keyswitch: ON.</li> </ul>	Laser diode on. Vanadate temperature servo on. LBO temperature servo on. Etalon temperature servo on.

## Turn-on



---

**Ensure the keyswitch is in the STANDBY position prior to performing the “Cold Start” Turn-on procedure. Turning the keyswitch to the ON position will result with the fault “LBO Not Locked at Set Temp” displayed until the LBO reaches operational temperature.**

---

### Turn-on (Cold-Start)

The cold-start procedure should be used when the Verdi V-2/V-5/V-6 power supply rear panel power switch has been off for longer than 30 minutes (laser in the OFF state as described in Table 4-1). In this condition, all servos are off and the Verdi has to stabilize the servos which can take up to 30 minutes. During this time, the laser diode cannot be turned on.

See the paragraph titled, “Second Harmonic Generator” on page 7-2 for additional information on the LBO heater ramp-up and stabilization.

Cold-start can also be accomplished when the laser is externally controlled by a computer. Refer to Table 5-3 on page 5-5 and Table 5-4 on page 5-6 for a list of RS-232 commands and queries.

Use the following procedure to perform a cold-start of the system.

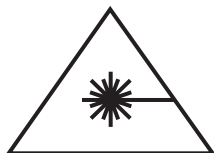
1. Ensure the keyswitch is in the STANDBY position.
2. Set the power switch on the power supply rear panel to “on.” The AC power and LASER EMISSION indicators will light. (See Table 6-1 on page 6-1 if an indicator does not light.) The power supply display will then indicate “System warming up”. Refer to Figure 4-4 on page 4-12 for the front panel displays and menus<sup>1</sup>.
3. Turn on the chiller. Verify there are no cooling line connection leaks at the Verdi riser/heat sink, and at the chiller.
4. Verify the chiller water temperature is set to approximately 20°C. Adjust the temperature setpoint as required.
5. Set the output power to the desired level using the POWER ADJUST knob. The output power can be adjusted to 0.01 watts to facilitate beam alignment.

---

1. Although the Verdi laser system will display zero operating hours, please note that the system was turned on and operated as part of our thorough manufacturing and final test procedures.

6. Allow 30 minutes for the heaters and thermo-electric coolers (TECs) to achieve operating temperature. The status of all servos can be viewed by scrolling to the Servo Status screen.

Once this process is complete, the display will indicate “Standby”. The system is now ready for key on.




---

**Ensure the laser output is blocked or directed at an intended target. Ensure all personnel in the area are wearing laser safety glasses.**

---

7. Open the shutter by pressing the SHUTTER OPEN pushbutton on the power supply front panel.
8. Laser light will emit from the laser head after the current ramp-up.

Coherent strongly recommends a weekly log book of diode current (read from front screen) vs. output power level is maintained. Such a record would prove to be very useful in troubleshooting.

### **LBO Optimization (Optional Step)**

If diode current increases 10% or more over the initial installation value (or current baseline value) to achieve the same output power, use the LBO Optimization menu shown in Table 4-5 on page 4-14 to access the LBO optimization routine. See the paragraph titled, “LBO Temperature Optimization” on page 6-40 for details on the LBO optimization procedure.

### **Daily Turn-on (Warm-Start)**

A warm-start can be performed when the Verdi power supply rear panel power switch has been on for more than 30 minutes (laser in standby as described in Table 4-1).

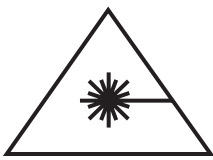
The recommended daily operation of the Verdi is to use this warm-start turn-on procedure in conjunction with the turn-off procedure that leaves the rear panel power switch in the “on” state.

If the power supply has been off for longer than 30 minutes (AC ON indicator not lit), perform the procedure in paragraph titled, “Turn-on (Cold-Start)”.

Warm-start can also be performed when the laser is externally controlled by a computer. Refer to Table 5-3 on page 5-5 and Table 5-4 on page 5-6 for a list of RS-232 commands and queries.

Use the following procedure to perform a warm-start of the system.

1. Verify there are no cooling line leaks at the Verdi riser/heat sink and at the chiller. Verify the chiller water temperature is set to 20°C. Adjust the setpoint temperature as required.
2. The LASER EMISSION indicator should be on. If the indicator is not on, refer to Table 6-1 on page 6-1. Turn the keyswitch on the power supply front panel to ON.
3. Once the keyswitch is in the ON position, the Main Display will appear on the power supply front panel display. Refer to Figure 4-4 on page 4-12 for a list of the display menus.



---

**Ensure the laser output is blocked or is directed at an intended target. Ensure all personnel in the area are wearing laser safety glasses.**

---

4. Laser light will emit from the laser head after current ramp-up.
5. Open the shutter by pressing the SHUTTER OPEN pushbutton on the power supply front panel.
6. If necessary, adjust the POWER ADJUST knob for the desired output power level. The output power can be adjusted to 0.01 watts to facilitate beam alignment.

Coherent strongly recommends a weekly log book of diode current (read from front screen) vs. output power level is maintained. Such a record would prove to be very useful in troubleshooting.

### **LBO Optimization (Optional Step)**

If diode current increases 10% or more over the initial installation value (or current baseline value) to achieve the same output power, use the LBO Optimization menu shown in Table 4-5 on page 4-14 to access the LBO optimization routine. See the paragraph titled, "LBO Temperature Optimization" on page 6-40 for details on the LBO optimization procedure.

### **Turn-off**

#### **Turn-off (Daily Use)**

When the Verdi is being used on a daily basis, turn-off consists of turning the keyswitch to the STANDBY position. This shuts off the laser diodes and places the Verdi in standby as described in Table 4-1 on page 4-1. This method avoids the heater ramp-up cycle described above in the paragraph titled, "Turn-on (Cold-Start)".




---

**Do not turn the power switch on the power supply rear panel to the OFF position. If all power is to be removed from the system, perform the procedure in paragraph titled, “Turn-off (Complete Shut-down)”.**

---

Turn-off daily use can also be performed when the laser is externally controlled by a computer. Refer to Table 5-3 on page 5-5 and Table 5-4 on page 5-6 for a list of RS-232 commands and queries.

### **Turn-off (Complete Shut-down)**

This procedure will remove all power from the Verdi and is recommended for performing system maintenance or if no operation is anticipated for extended periods of time. Use the cold-start procedure to turn the Verdi back on after a complete shut-down.

Complete shut-down can also be performed when the laser is externally controlled by a computer. Refer to Table 5-3 on page 5-5 and Table 5-4 on page 5-6 for a list of RS-232 commands and queries.

1. Turn the keyswitch power supply front panel to STANDBY.
2. Access and select the LBO Settings submenu. Press the MENU SELECT pushbutton to start the LBO cool-down cycle.




---

**To avoid unnecessary use of the backup battery, do not turn the power switch on the power supply rear panel to the OFF position while the Verdi is in the cool-down cycle. This takes approximately 30 minutes.**

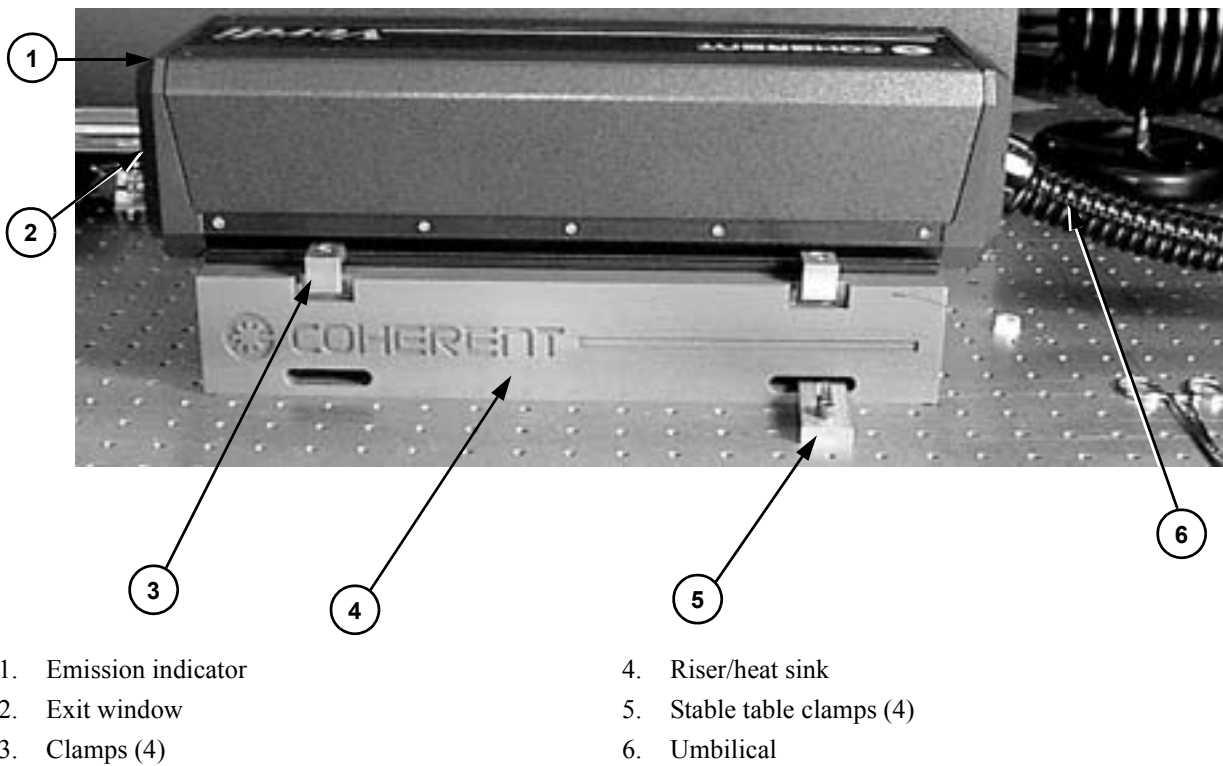
---

3. During the cool-down cycle, the LBO temperature can be monitored from the main screen or the LBO Settings submenu. When the LBO temperature decreases below 40°C, turn the AC power switch on the power supply rear panel to the OFF position.

Removing AC power from the power supply will cause the internal battery to complete the LBO cool-down cycle. This causes unnecessary drain on the battery. For maximum battery life, use the LBO cool down menu. Refer to the paragraph titled, “Battery Backup” on page 7-8 for more information.

4. Turn off the chiller if equipped with the system.

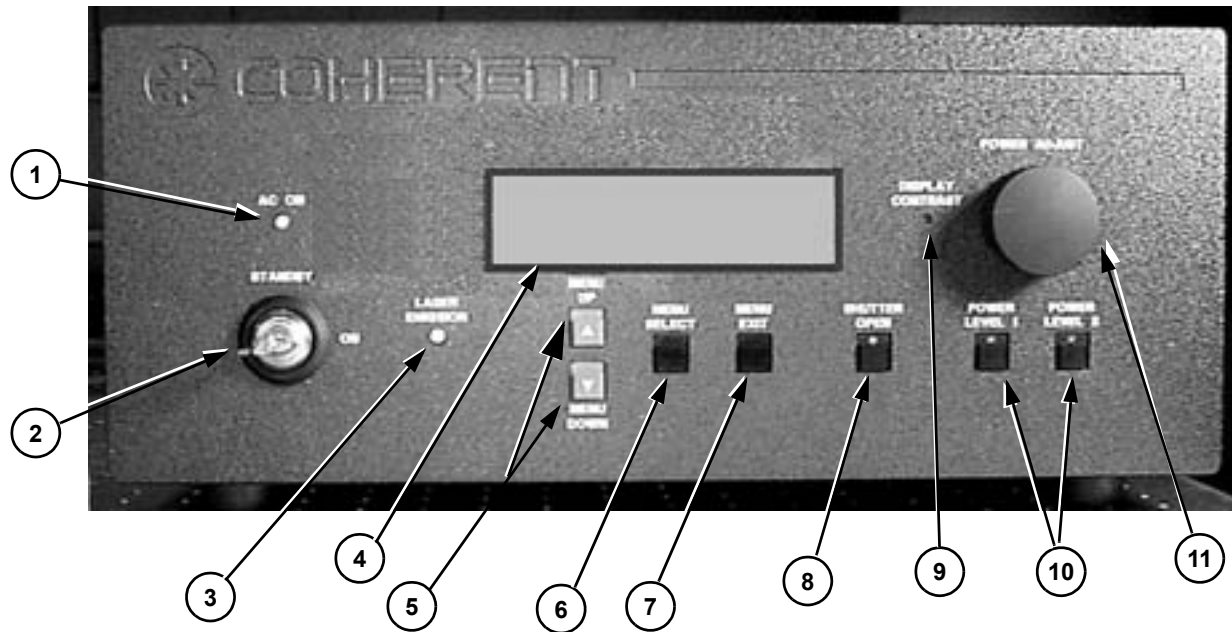
## Controls, Indicators, and Features



**Figure 4-1. Laser Head Features**

**Table 4-2. Laser Head Features**

<b>ITEM</b>	<b>CONTROL</b>	<b>FUNCTION</b>
1	Emission indicator	Lights when laser emission is possible.
2	Exit window	532 nm laser light is emitted from this window when the laser is on and the shutter is open.
3	Clamps (4)	Secures the laser head to the riser/heat sink.
4	Riser/Heat sink	The passive riser/heat sink transfers heat from the laser head baseplate to the mounting surface. The mounting surface must be capable of dissipating the transferred heat such that the baseplate temperature does not exceed 55°C.  The optional water-cooled riser/heat sink needs no additional mounting surface to maintain the base temperature below 55°C.
5	Optical table clamps (4)	Secures the heat sink to the mounting surface.  The mounting surface must be capable of dissipating the transferred heat such that the baseplate temperature does not exceed 55°C.
6	Umbilical	Houses the fiber optic and electrical cables that provides an interface between the laser head and power supply.



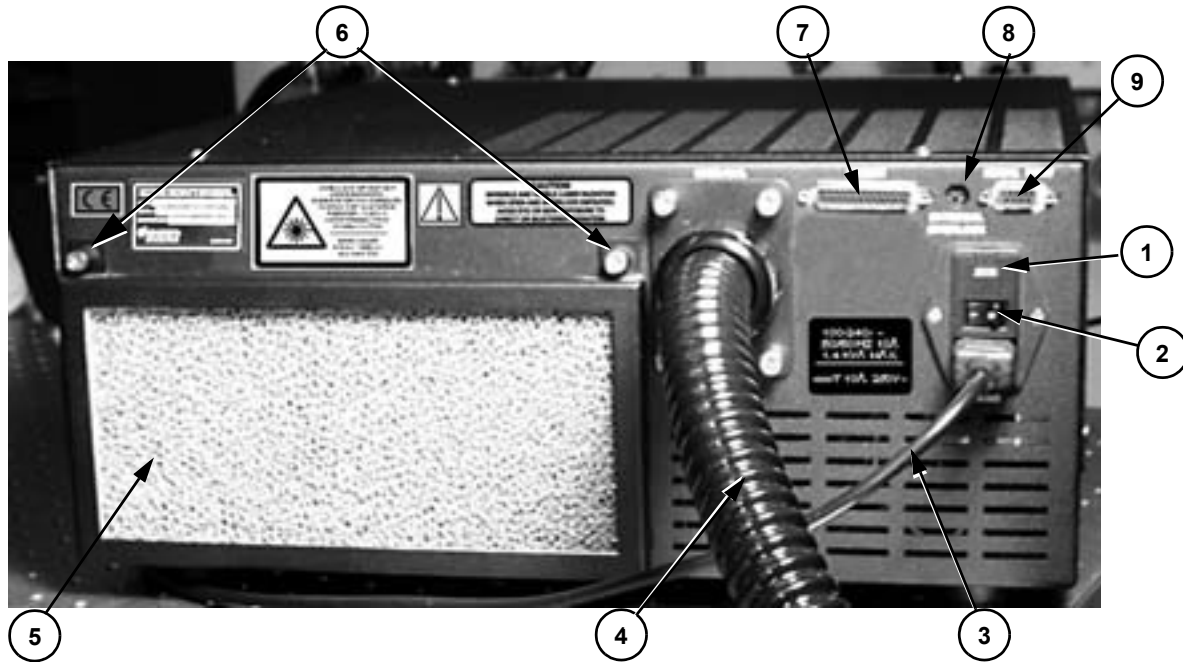
- |                             |   |
|-----------------------------|---|
| 1. AC ON indicator          | 7. MENU EXIT pushbutton                   |
| 2. Key switch               | 8. SHUTTER OPEN pushbutton indicator      |
| 3. LASER EMISSION indicator | 9. DISPLAY CONTRAST adjust                |
| 4. Display                  | 10. POWER LEVEL 1/2 pushbutton indicators |
| 5. MENU UP/DOWN pushbuttons | 11. POWER ADJUST knob                     |
| 6. MENU SELECT pushbutton   |   |

**Figure 4-2. Power Supply Front Panel Controls and Indicators**



**Table 4-3. Power Supply Front Panel Controls and Indicators**

<b>ITEM</b>	<b>CONTROL</b>	<b>FUNCTION</b>
1	AC ON indicator	Lights when power is applied to the power supply via the power switch on the rear panel.
2	Key switch	The key switch can place the Verdi V-2/V-5/V-6 either in the STANDBY or ON state. Functionality in these states are summarized in Table 4-1. The key can be removed when in STANDBY position to prevent unauthorized operation. The key cannot be removed when in ON position.
3	LASER EMISSION indicator	Lights when laser emission is possible.
4	Display	Displays system status, operating parameters, and diagnostic data. Refer to Figure 4-4 for a description of the displays.
5	MENU UP/DOWN pushbuttons	Allows scrolling through the menus. Refer to Figure 4-4 for a description of the displays and menus.
6	MENU SELECT push-button	Allows selection of the indicated menu.
7	MENU EXIT push-button	Exits current menu. Can also be used to clear inactive faults as described in the troubleshooting charts in Section Six, Maintenance and Service.
8	SHUTTER OPEN pushbutton indicator	Remotely opens and closes the external shutter on the laser head. When the shutter is closed, the laser will go to idle at minimum power. If the POWER ADJUST knob is not touched after the shutter is closed, the laser will return that power setting once the shutter is opened. If the POWER ADJUST knob is adjusted after the shutter is closed, then the laser will ramp to the new setting after the shutter is opened.
9	DISPLAY CONTRAST adjust	Allows adjustment of the display by user for best viewing.
10	POWER LEVEL 1/2 pushbutton indicators	Allows selection of 2 preset laser output power levels. To preset a power level, press the pushbutton to light the LED. Use the POWER ADJUST knob to set the power, then press the pushbutton again so that the LED is off. The new power value is then stored.
11	POWER ADJUST knob	Allows continuous adjustment of output power level from threshold to maximum power.



- |                        |                                  |
|------------------------|----------------------------------|
| 1. Fuses               | 6. Air filter retaining nuts (2) |
| 2. Power ON/OFF switch | 7. Reserved connector            |
| 3. Power cord          | 8. EXTERNAL INTERLOCK connector  |
| 4. Umbilical           | 9. SERIAL PORT connector         |
| 5. Air filter          |                                  |

**Figure 4-3. Power Supply Rear Panel Controls and Indicators**

**Table 4-4. Power Supply Rear Panel Controls and Indicators**

<b>ITEM</b>	<b>CONTROL</b>	<b>FUNCTION</b>
1	Fuse	250 V, 10 A, time delay fuse provides electrical protection.
2	Power ON/OFF switch	Applies/removes all power from the Verdi V-2/V-5/V-6. Refer to the shut-down procedures to avoid unnecessary use of the internal battery.
3	Power cord	Connects the power supply to AC facility power.
4	Umbilical	Houses electrical and fiber optic cables.
5	Air filter	Removes dirt and contamination from the power supply cooling air.
6	Air filter retaining nuts	Secures air filter to power supply.
7	Reserved connector	Reserved for future use.
8	EXTERNAL INTER-LOCK connector	Allows connection of an external interlock. The laser will not operate when this connector is open. Refer to the Section Three, Installation, for additional information on the interlock.
9	SERIAL PORT connector	Allows external computer control of the Verdi V-2/V-5/V-6. Refer to Section Five for additional information on external computer control including commands, queries, and system requirements.

## Menu Displays

Figure 4-4 shows the Verdi Main Display and the Base Menu screens. The Base Menu screen can be reached from the Main Display screen by pressing the SELECT pushbutton on the power supply front panel. Once in the Base Menu screen, the user can return to the Main Display screen by pressing the power supply EXIT pushbutton.

Navigation through a list of submenus, such as those in the Base Menu screen, is achieved by pressing the UP and DOWN arrow keys on the power supply front cover. When the selection arrow (see Figure 4-4) points to the desired submenu, that item can be activated by pressing the SELECT pushbutton. Pressing the EXIT pushbutton will deactivate the submenu, and re-display the Base Menu screen. Examples and explanations for all Verdi submenus can be found in Table 4-5.

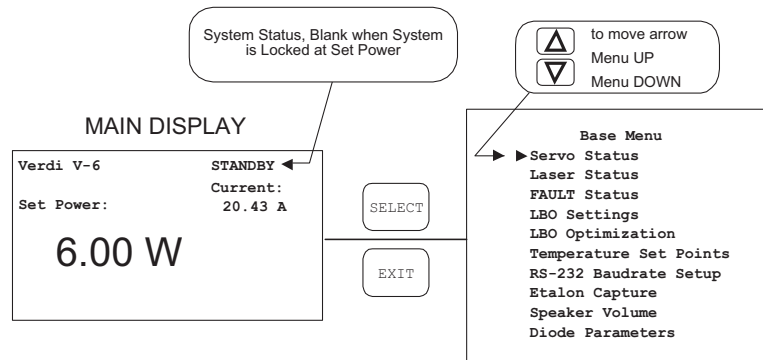


Figure 4-4. Menus

## System Status Messages

The current status of the laser system is displayed in the upper right-hand corner of the Main Display screen of the software (see Figure 4-4). Possible messages are:

- **System Warming Up:** Displayed while LBO crystal is heating.
- **Standby.** Displayed if power supply front panel keyswitch is in the STANDBY position.
- **Laser Seeking.** Displayed while system is ramping the diode current up to achieve set power. If the system is displaying this message while the diode current is not changing, one or more servo loops in the seek mode of operation. See the software Servo Status Screen for additional information.
- **Shutter Closed.** Displayed if system head shutter has not been opened.

- **Fault Active.** Displayed if there is an active system fault. See the Fault Status Screen for additional information.
- **RS-232 Key Standby.** Displayed if the laser system is placed in STANDBY via the RS-232 command.

## Fault Handling

In case of a fault, the CPU closes the shutter, sets the laser diode current to zero, and displays the Fault Status Screen. For example:

```
!!!!!!!!!!!!!!!!!!!!!!!!!!!!
      FAULT CONDITION!
      ERROR CODE #16
      Diode 1 Over Current Fault
      !!!!!!!!!!!!!!!!!!!!!!!!!!!!!

      Push EXIT to continue
```

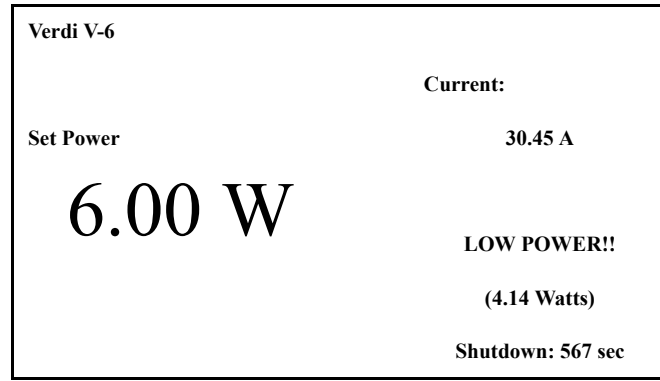
To clear a fault, the appropriate troubleshooting steps should be taken. The power supply keyswitch should be turned to the STANDBY position and the EXIT pushbutton pressed. See Table 6-1 on page 6-1 for a complete listing of system faults and troubleshooting procedures.

When the condition that caused the fault no longer exists, exit the Fault Status screen to clear the fault. Once the keyswitch is turned to the ON position, laser operation returns to its pre-fault state, except the shutter will remain closed.

If the fault condition still exists, the system message “FAULT ACTIVE” will be displayed in the Main Display screen.

## Low Power Warning

If the system maximum diode drive current is reached, and the requested output power is not obtained, the power supply will beep and a "LOW POWER!!" warning message will be displayed in the lower right-hand corner of the Main Display screen.



If this message is observed, the output power setpoint should be decreased until it is less than the value in the warning message and the LBO optimization procedure should be run. If the warning message reappears after LBO optimization, contact your local Coherent service representative.

If the output power setpoint is not decreased, the system will shut down with a "Diode Over Current" fault after 600 seconds has elapsed.

**Table 4-5. Submenus (Sheet 1 of 3)**

Servo Status Screen			
Servo:	State	W/deg C	Drive
Laser:	lock	5.00	21000
LBO:	lock	146.00	4784
Vanadate:	lock	30.00	-1776
Vanadate 2:	lock	30.00	-1776
Etalon:	lock	46.00	428
Diode 1:	*seek	16.51	-1413

Displays the Verdi servo status: "OPEN," "LOCK," "SEEK," "\*SEEK," or "FAULT." The value for the laser light loop servo is in Watts and the other values (temperature servos) are °C.

\*SEEK indicates the algorithm optimizing the diode temperature is running. This algorithm optimizes the diode temperature such that maximum laser rod absorption of the IR pump is achieved. Functionally, this lowers the diode pump power, and thus operating current, necessary to achieve specified power. \*SEEK is invoked automatically provided the system is running at 80% or greater output power.

Laser Status Screen			
S/W Version	:	8.82, 9/2/99	
Heatsink #1 T	:	22.32 C	
Baseplate T	:	28.40 C	
HEAD Hrs	:	54.75	Sys: 7/23/99
DIODE1 Hrs	:	64.05	I: 24.40 A

Displays Verdi V-2/V-5/V-6 status and system information.

**Table 4-5. Submenus (Sheet 2 of 3)**

Fault Status Screen

SYSTEM OK:

If faults are active, the fault codes and descriptions will be displayed. Refer to Table 6-1 on page 6-1 for a complete list of faults and associated corrective actions. Refer to the paragraph titled, "Fault Handling" for additional information on how to clear faults.

LBO Settings

T: 146.04 Set: 146.00  
Drive: 4788

LBO Heating

Press SELECT to start COOLING  
Press EXIT for NO CHANGE

Displays the state of the LBO servo (heating or cooling).

Access this menu to initiate heating or cooling of the LBO crystal. For example, the cool-down cycle is initiated from this menu during the "Complete Shutdown" procedure.

LBO Optimization

T: 143.90 Pwr: 4.74 Drv: 6007

OK to OPTIMIZE LBO Temp

Press SELECT to OPTIMIZE Tlbo  
Press EXIT to ABORT

This menu is used to initiate LBO optimization. See paragraph titled, "LBO Temperature Optimization" on page 6-40 for additional information and procedures regarding LBO optimization.

Temperature Set Points

Set Pt: 144.00 Drive: 5950.0  
Read T: 144.00 Status: lock  
Set Pwr: 5.00W Avg I: 23.28A

->LBO Temperature  
Vanadate Temperature  
...Etalon Temperature  
Diode #1 Temperature

Displays the various system temperature set points, actual temperatures, and DAC drives required by the servo loops. Temperatures cannot be changed from this menu.

RS-232 Baudrate Setup

RS-232 Protocol: 38400, 8, N, 1

Use KNOB to adjust rate values

Press SELECT to ACCEPT  
Press EXIT to ABORT

Allows adjustment of the baud rate (factory set to 19,200) for RS-232 communications. See paragraph titled, "Setting The Baud Rate" on page 5-3 for additional information on baud rate.

**Table 4-5. Submenus (Sheet 3 of 3)**

Etalon Capture Screen

Press SELECT to Capture Mode  
Press EXIT to return to menu

The Etalon Capture Screen momentarily reduces the diode current below lasing threshold to allow the single-frequency mode to re-center. Re-centering is implemented each time the laser is turned on.

Speaker Volume Screen

-> Speaker Volume HIGH  
Speaker Volume MEDIUM  
Speaker Volume LOW  
Speaker Volume OFF

Press SELECT to change  
Press EXIT when done

The Speaker Volume Screen allows the audible beep (fault) volume to be adjusted.

Diode Parameters Screen

Diode 1 Voltage : 1.80V  
Diode 1 Current : 17.50A  
Diode 1 Photocell : 2.50V

Displays diode voltage, current, and photocell values for the diodes. Coherent recommends recording these values periodically to help assess the health of the system.

The diode photocell voltage should be approximately 2.50 V, at maximum output power level.



## SECTION FIVE: EXTERNAL COMPUTER CONTROL

### **How to Interface Verdi Lasers**

This section provides details on how to interface a Verdi V-2/V-5/V-6 laser to a remote computer via the RS-232 connector on the rear of the power supply.

The RS-232 interface is based on a set of laser control instructions, consisting of commands that affect laser operation, and queries that request the laser to return status information to the host. The instruction set is sufficient to support user-written programs that emulate the functions of the Verdi front panel.

### **RS-232 Command Language**

#### **Instruction Syntax for RS-232 Communication**

Communication with the Verdi is with two types of instructions:

- Commands which set the values of laser operating parameters.
- Queries which request the laser to return the value of an operating parameter.

Any instruction to the laser consists of a command or query written as a string of ASCII characters and terminated by a carriage return and linefeed (<CR><LF>) or a semicolon (;).

For example:

**LASER = 1**<CR><LF>

Switches the Verdi from STANDBY to ON.

**?LIGHT**<CR><LF>

Requests the laser to return the measured laser output power.

The laser will always respond to an instruction by returning a message terminated by a carriage return and linefeed. Table 5-1 lists the possible responses from the laser.

**Table 5-1. Response from Laser after Receiving Instruction**

INSTRUCTION SENT TO LASER	RESPONSE FROM LASER			
	ECHO OFF PROMPT OFF	ECHO OFF PROMPT ON	ECHO ON PROMPT OFF	ECHO ON PROMPT ON
Command + <CR><LF>	<CR><LF>	Verdi><CR> <LF>	Command + <CR><LF>	Verdi> Command + <CR><LF>
Query + <CR><LF>	Data + <CR><LF>	Verdi> Data + <CR><LF>	Query + Data + <CR><LF>	Verdi> Query + Data + <CR><LF>
Command + <CR><LF> (Illegal operand)	RANGE ERROR: + Command + <CR><LF>	Verdi> RANGE ERROR: + Command + <CR><LF>	Command + RANGE ERROR: + Command + <CR><LF>	Verdi> Command + RANGE ERROR: + Command + <CR><LF>
Command <CR><LF> (Illegal instruction)	Command Error: + Command + <CR><LF>	Verdi> Command Error: + Command + <CR><LF>	Command + Command Error: + Command + <CR><LF>	Verdi> Command + Command Error: + Command + <CR><LF>
Query<CR><LF> (Illegal instruction)	Query Error: + Query + <CR><LF>	Verdi> Query Error: + Query + <CR><LF>	Query + Query Error: + Query + <CR><LF>	Verdi> Query + Query Error: + Query + <CR><LF>
1. Multiple items will be separated by the "&" character. For example, a list of system faults will be returned as "3&5&6."				




---

**For proper handshaking, communication programs should wait until the <CR><LF> has been returned from the laser before sending the next instruction.**

---

**ECHO Mode**

The Verdi provides an "echo" mode in which each character transmitted to the laser is echoed to the host. This feature can be turned on or off using the ECHO command.

**PROMPT Mode**

The Verdi provides a "prompt" mode for terminal operation in which the laser returns; for example, "Verdi>" after each command. This feature can be turned on or off using the "PROMPT" command.

**?** The single character “?” may be substituted for “PRINT” in all queries. For example:

**?LIGHT** is equivalent to **PRINT LIGHT**

**= or :** The single characters = and : are equivalent delimiters between text and data in all commands. For example:

**LASER = 0** is equivalent to **LASER: 0**

## RS-232 Interface Connection

The Verdi Laser’s RS-232 port configuration is described in Table 5-2, and typical cable requirements are shown in Figure 5-1. The 9-pin RS-232 port is configured as data communications equipment (DCE) device using only pins 2 (serial data out), 3 (serial data in) and 5 (signal ground). Handshake lines RTS, CTS, DTR and DSR (pins 4, 6, 7 and 8) are not used and have no connections inside the power supply.

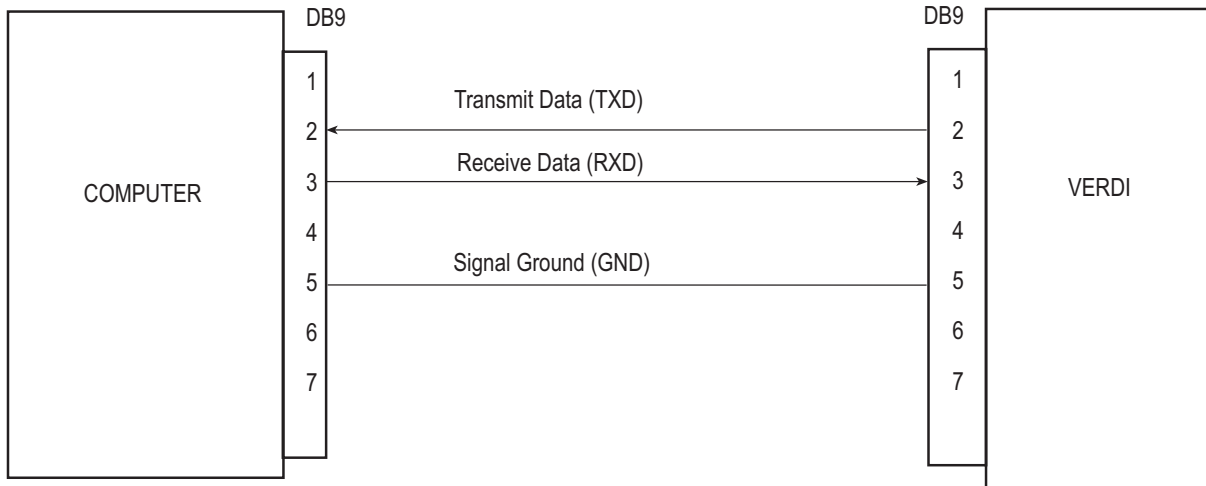
## RS-232 Port Configuration

*Table 5-2. RS-232 Port Description*

CONFIGURATION	DCE, NO HANDSHAKING
Data bits	8
Stop bits	1
Parity	none
Baud rate	User selectable: 1200 2400 4800 9600 19200 (default factory setting) 38400 57600

## Setting The Baud Rate

The baud rate of the 9-pin RS-232 port can be adjusted through the “RS-232 Baudrate Setup” menu on the front panel (Figure 4-4 on page 4-12) or via the SERIAL BAUDRATE = NNN command described in Table 5-1 and Table 5-2. After the baud rate is changed,



**Figure 5-1. RS-232 Pin Configuration**

the new setting will be used until it is changed even if the system power is switched off.

To set the baud rate by the remote computer, send the **SERIAL BAUDRATE = NNN** command to the laser at the currently set baud rate. After sending this baud rate command, host computer communications port must be reinitialized to the new baud rate.

The factory set baud rate is 19200.



---

**When an RS-232 command is issued to change a setting, the display may not update to reflect the changes taking place in the system. The user should press MENU EXIT and MENU SELECT to update the display.**

---

## **Instruction Set**

Tables 5-3 and 5-4 describe the instructions (long and short forms) for use in RS-232 with the Verdi.

Table 5-3. RS-232 Commands

COMMANDS	ACTION PERFORMED
BAUDRATE = nnnnn B = n	Sets the RS-232 Serial port baud rate to the specified value. nnnnn = 1200, 2400, 4800, 9600, 19200, 38400, 57600.
CHILLER	Available only with Coherent-supplied chiller (part number1037271). = ON, = XX.X
ECHO = n E = n	If n = 0: turns echo OFF. Characters transmitted to the laser will not be echoed to the host. If n = 1: turns echo ON. Characters transmitted to the laser will be echoed to the host. A change in echo mode will take effect with the first command sent after the echo command.
EXIT SCREEN = 1 EXIT = 1	Duplicates EXIT button.
FLASH = 1 FL = 1	Flashes laser output below lasing threshold to allow single-frequency mode (Etalon) to recenter.
KNOB DOWN= 1 KNOBDN = 1	Duplicates KNOB DOWN button.
LASER = n L = n	If n = 0: puts laser in STANDBY (note: If the key is in the "ON" position, then n = 0 will override) If n = 1: resets faults and turns laser on (key must be in the "ON" position) Clears fault screen on power supply and fault history (?FAULT HISTORY) so lasing will resume if no active faults
LBO HEATER = n LBOH = n	If n = 0: turns LBO heater off (COOL DOWN) If n = 1: turns LBO heater on (HEATING)
LBO OPTIMIZE = n LBOOPT	Initiates the LBO optimization. 1 = optimize
LIGHT = nn.nnnn P = nn.nnnn	Sets light regulation to the specified output power.
LOCK FRONT PANEL = n LFP = n	Disables user input from the front panel.
MENU DOWN = 1 MENUDN = 1	Duplicates MENU DOWN button.
MENU SELECT= 1 SELECT = 1	Duplicates MENU SELECT button.
MENU UP = 1 MENUUP= 1	Duplicates MENU UP button.

**Table 5-3. RS-232 Commands (Continued)**

COMMANDS	ACTION PERFORMED
POWER = n P = nn.nnnn	Sets light regulation to the specified output power.
PRINT	Works the same as a query; must be followed by a space
PROMPT = n > = n	If n = 0: turns "Verdi>" prompt on If n = 1: turns "Verdi>" prompt off
SHUTTER = n S = n	If n = 0: closes external shutter If n = 1: opens external shutter

**Table 5-4. RS-232 Queries (Sheet 1 of 5)**

QUERIES	RETURNED INFORMATION
PRINT AVG CURRENT AND DELTA ?ACAD	Returns the average diode current and the difference between them.
PRINT BASEPLATE TEMP ?BT	Returns laser head baseplate measured temperature, nn.nn, in °C.
PRINT BAUD RATE ?B	Returns the baud rate of the Verdi V-2/V-5/V-6 serial port.
PRINT CURRENT ?C	Returns the measured average diode current, nn.n, in amps.
PRINT DIODE1 CURRENT ?D1C	Returns laser diode #1 measured current, nn.n, in amps.
PRINT DIODE1 HEATSINK TEMP ?D1HST	Returns laser diode #1 heat sink measured temperature, nn.nn, in °C.
PRINT DIODE1 HOURS ?D1H	Returns the number of operating hours on laser diode 1.
PRINT DIODE1 PHOTOCCELL ?D1PC	Returns light output power from diode 1 photocell.
PRINT DIODE1 RATED CURRENT FACTOR ?D1RCF	Returns the factor that accounts for diode aging for diode 1.
PRINT DIODE1 RATED CURRENT MAX ?D1RCM	Returns the maximum current at which diode 1 will be allowed to operate.

Table 5-4. RS-232 Queries (Sheet 2 of 5)

QUERIES	RETURNED INFORMATION
PRINT DIODE1 SERVO STATUS ?D1SS	Returns the status of diode #1 temperature servo: 0 if the servo is OPEN 1 if the servo is LOCKED 2 if the servo is SEEKING 3 if the servo has a FAULT 4 if the servo is OPTIMIZING 5 if the servo is CPEAKING (Not available for V5 UNO, V6) 6 if the servo is CPEAKING2 (For V5 UNO, V6 only)
PRINT DIODE1 SET TEMP ?D1ST	Returns laser diode #1 set temperature, nn.nn, in °C.
PRINT DIODE1 TEMP DRIVE ?D1TD	Returns laser diode #1 temperature servo drive setting.
PRINT DIODE1 TEMP ?D1T	Returns laser diode #1 measured temperature, nn.nn, in °C.
PRINT DIODE1 5VREF SENSE ?D15V	Returns a reference voltage used to measure the temperature of Diode 1.
PRINT DIODE OPTIMIZER STATUS ?DIOS	Returns diode optimizer status. 1 if the system is able to optimize 0 if not
PRINT ETALON DRIVE ?ED	Returns etalon temperature servo drive setting.
PRINT ETALON SERVO STATUS ?ESS	Returns the status of the etalon temperature servo: 0 if the servo is OPEN. 1 if the servo is LOCKED. 2 if the servo is SEEKING. 3 if the servo has a FAULT.
PRINT ETALON SET TEMP ?EST	Returns etalon set temperature, nn.nn, in °C.
PRINT ETALON TEMP ?ET	Returns measured Etalon temperature, nn.nn, in °C.

**Table 5-4. RS-232 Queries (Sheet 3 of 5)**

QUERIES	RETURNED INFORMATION
PRINT FAULTS ?F	1 = Laser Head Interlock Fault 2 = External Interlock Fault 3 = PS Cover Interlock Fault 4 = LBO Temperature Fault 5 = LBO Not Locked at Set Temp 6 = Vanadate Temp. Fault 7 = Etalon Temp. Fault 8 = Diode 1 Temp. Fault 10 = Baseplate Temp. Fault 11 = Heatsink 1 Temp. Fault 16 = Diode 1 Over Current Fault 18 = Over Current Fault 19 = Diode 1 Under Volt Fault 21 = Diode 1 Over Volt Fault 25 = Diode 1 EEPROM Fault 27 = Laser Head EEPROM Fault 28 = Power Supply EEPROM Fault 29 = PS-Head Mismatch Fault 31 = Shutter State Mismatch 40 = Head-Diode Mismatch Fault 47 = Vanadate2 Temp. Fault
PRINT FAULT HISTORY ?FH	Returns a list of number codes (see ?F) for all faults that have occurred since the last LASER ON command, separated by an "&", or return SYSTEM OK if no latched faults. To clear the fault screen, when the fault is active, enter the LASER ON command or the EXIT button on the power supply
PRINT HEAD_HOURS ?HH	Returns the number of operating hours on the system head.
PRINT KEYSWITCH ?K	Returns: 0 if the keyswitch is OFF 1 if the keyswitch is ON
PRINT LASER ?L	Returns: 0 if the laser is OFF (STANDBY) 1 if the laser is in ON 2 if the laser is OFF due to fault (check faults or fault history)
PRINT LBO DRIVE ?LBOD	Returns LBO temperature servo drive setting.
PRINT LBO HEATER ?LBOH	Returns the status of the LBO heater: 0 if the LBO heater is OFF (COOL DOWN) 1 if the LBO heater is ON (HEATING)
PRINT LBO OPTIMIZER STATUS ?LBOOS	Returns the LBO optimizer status: 1 if the system is able to run the LBO optimization 0 if not
PRINT LBO SET TEMP ?LBOST	Returns LBO set temperature, nnn.nn, in °C.



Table 5-4. RS-232 Queries (Sheet 4 of 5)

QUERIES	RETURNED INFORMATION
PRINT LBO SERVO STATUS ?LBOSS	Returns the status of the LBO temperature servo: 0 if the servo is OPEN 1 if the servo is LOCKED 2 if the servo is SEEKING 3 if the servo has a FAULT 4 if the servo is OPTIMIZING 5 if the servo is CPEAKING (Not available for V5 UNO, V6) 6 if the servo is CPEAKING2 (Only available for V5 UNO, V6)
PRINT LBO TEMP ?LBOT	Returns LBO measured temperature, nnn.nn, in °C.
PRINT LIGHT ?P	Returns the calibrated output power, nn.nnn, in watts.
PRINT LIGHT REG STATUS ?LRS	Returns the status of the light loop servo: 0 if the servo is OPEN (current regulation) 1 if the servo is LOCKED 2 if the servo is SEEKING 3 if the servo has a FAULT
PRINT MODE ?M	Returns the mode of operation, whether current or light control. 1 = light, 0 = current
PRINT PS HOURS ?PSH	Returns the number of power supply operating hours.
PRINT SET LIGHT ?SP	Returns the light regulation set power, nn.nnnn, in watts.
PRINT SHUTTER ?S	Returns the status of the external shutter: 0 if the shutter CLOSED 1 if the shutter OPEN
PRINT SOFTWARE ?SV	Returns the power supply software version number.
PRINT VANADATE SET TEMP ?VST	Returns vanadate #1 set temperature, nn.nn, in °C
PRINT VANADATE TEMP ?VT	Returns vanadate #1 measured temperature, nn.nn, in °C.

**Table 5-4. RS-232 Queries (Sheet 5 of 5)**

<b>QUERIES</b>	<b>RETURNED INFORMATION</b>
PRINT VANADATE DRIVE ?VD	Returns vanadate #1 temperature servo drive setting
PRINT VANADATE SERVO STATUS ?VSS	Returns the status of the vanadate temperature servo: 0 if the servo is OPEN 1 if the servo is LOCKED 2 if the servo is SEEKING 3 if the servo has a FAULT

## SECTION SIX: MAINTENANCE AND SERVICE




---

**Do not open the Verdi V-2/V-5/V-6 laser head. There are no user-serviceable components or adjustments inside. There are hazardous levels of laser energy inside the laser head. There is no cover interlock to eliminate these dangers upon removal of the laser head cover.**

---

### **Troubleshooting**

Table 6-1 lists possible problems/error messages with a reference to the associated troubleshooting chart located in this section.

**Table 6-1. Troubleshooting/Fault Messages (Sheet 1 of 3)**

<b>PROBLEM</b>	<b>TROUBLESHOOTING REFERENCE</b>
Laser does not start (no laser output)	Chart 1
Laser shuts down	Chart 2
Laser output unstable	Chart 3
AC ON indicator on power supply front panel does not light when power switch on rear panel is on.	Chart 4
LASER EMISSION indicator on power supply front panel or on the laser head does not light when keyswitch is in the “ON” position.	See note [1]
Diode currents increase by 10% of baseline current.	Chart 11
[1] Contact Coherent or an authorized representative. If the laser system or components are being returned directly to Coherent, an RMA (Return Material Authorization) number is required.	

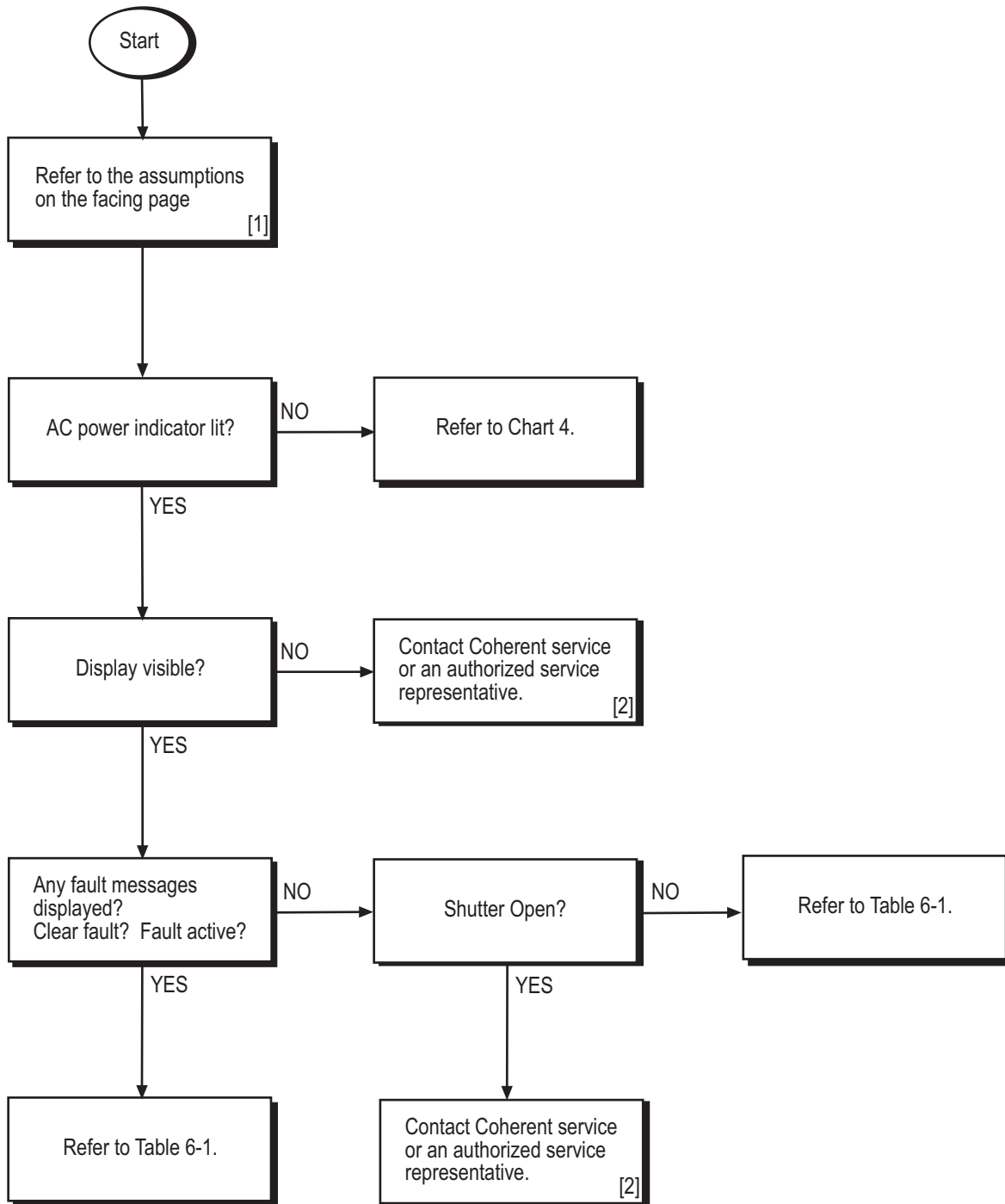
**Table 6-1. Troubleshooting/Fault Messages (Sheet 2 of 3)**

<b>PROBLEM</b>	<b>TROUBLESHOOTING REFERENCE</b>
<b>FAULT MESSAGES:</b>	
Fault Code 1: Laser Emission Lamp Fault	Chart 5
Fault Code 2: External Interlock Fault	Chart 6
Fault Code 3: PS Cover Interlock Fault	Chart 7
Fault Code 4: LBO Temperature Fault	Chart 8
Fault Code 5: LBO Not Locked at Set Temperature	Chart 12
Fault Code 6: Vanadate Temperature Fault	Chart 8
Fault Code 7: Etalon Temperature Fault	Chart 8
Fault Code 8: Diode 1 Temperature Fault	Chart 8
Fault Code 10: Baseplate Temperature Fault	Chart 9
Fault Code 11: Diode Heat Sink 1 Temperature Fault	Chart 10
Fault Code 16: Diode 1 Over Current Fault	Chart 11
Fault Code 18: Over Current Fault	Chart 11
Fault Code 19: Diode 1 Under Voltage Fault	Chart 12
Fault Code 21: Diode 1 Over Voltage Fault	Chart 12
Fault Code 25: Diode 1 EEPROM Fault	Chart 12
Fault Code 27: Laser Head EEPROM Fault	Chart 12
Fault Code 28: Power Supply EEPROM Fault	Chart 12
Fault Code 29: Power Supply-Head Mismatch Fault	Chart 12
Fault Code 30: Battery Requires Service	Chart 13

**Table 6-1. Troubleshooting/Fault Messages (Sheet 3 of 3)**

<b>PROBLEM</b>	<b>TROUBLESHOOTING REFERENCE</b>
Fault Code 31: Shutter State Mismatch	Chart 12
Fault Code 40: Head-Diode Mismatch Fault	Chart 12

**Chart 1. Laser Does Not Start (No Light Output)**



## **Chart 1. Laser Does Not Start (No Light Output) [Continued]**

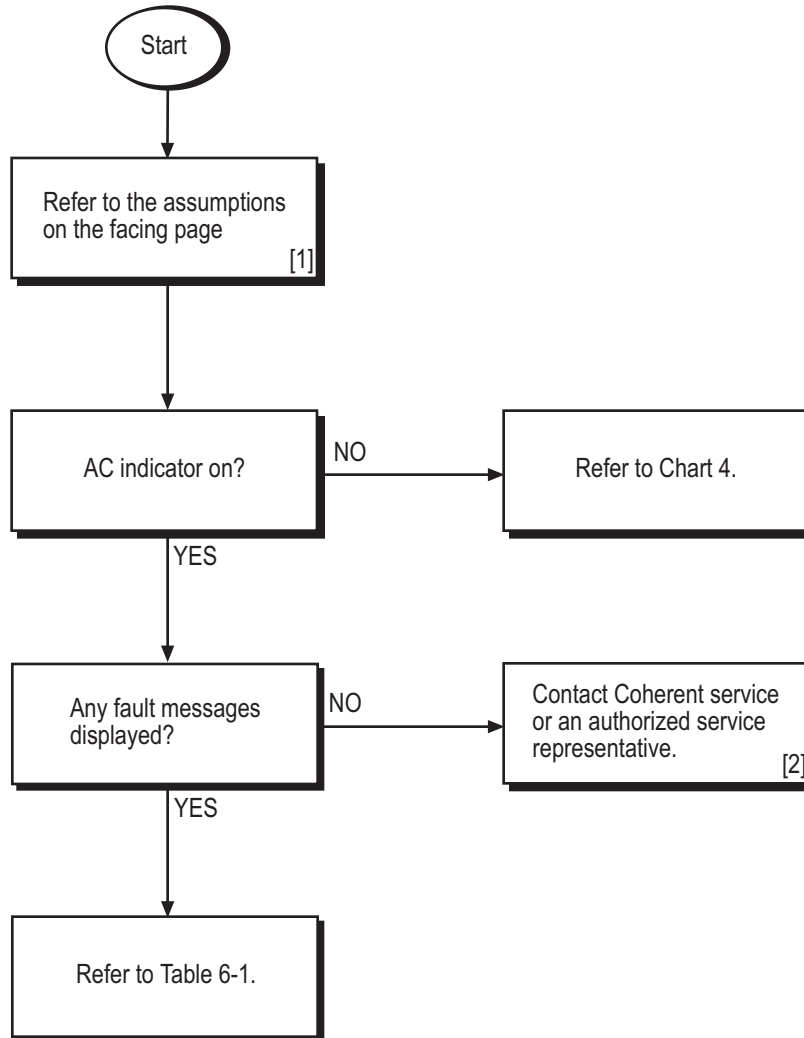
**The numbered paragraphs below are keyed to supplement this flowchart.**

**[1]** ASSUMPTIONS:

- The laser system has been installed in accordance with the installation procedures in Section Three: Installation.
- This procedure is not intended to re-start a laser after it has shut down due to a fault.
- A closed shutter is not blocking output light.
- The appropriate turn-on procedures are performed and the laser is not in a warm-up cycle.

**[2]** If the laser system must be returned directly to Coherent, an RMA (Return Material Authorization) number is required. Contact Coherent or an authorized representative.

## Chart 2. Laser Shuts Down (No Light Output)





## **Chart 2. Laser Shuts Down (No Light Output) [Continued]**

**The numbered paragraphs below are keyed to supplement this flowchart.**

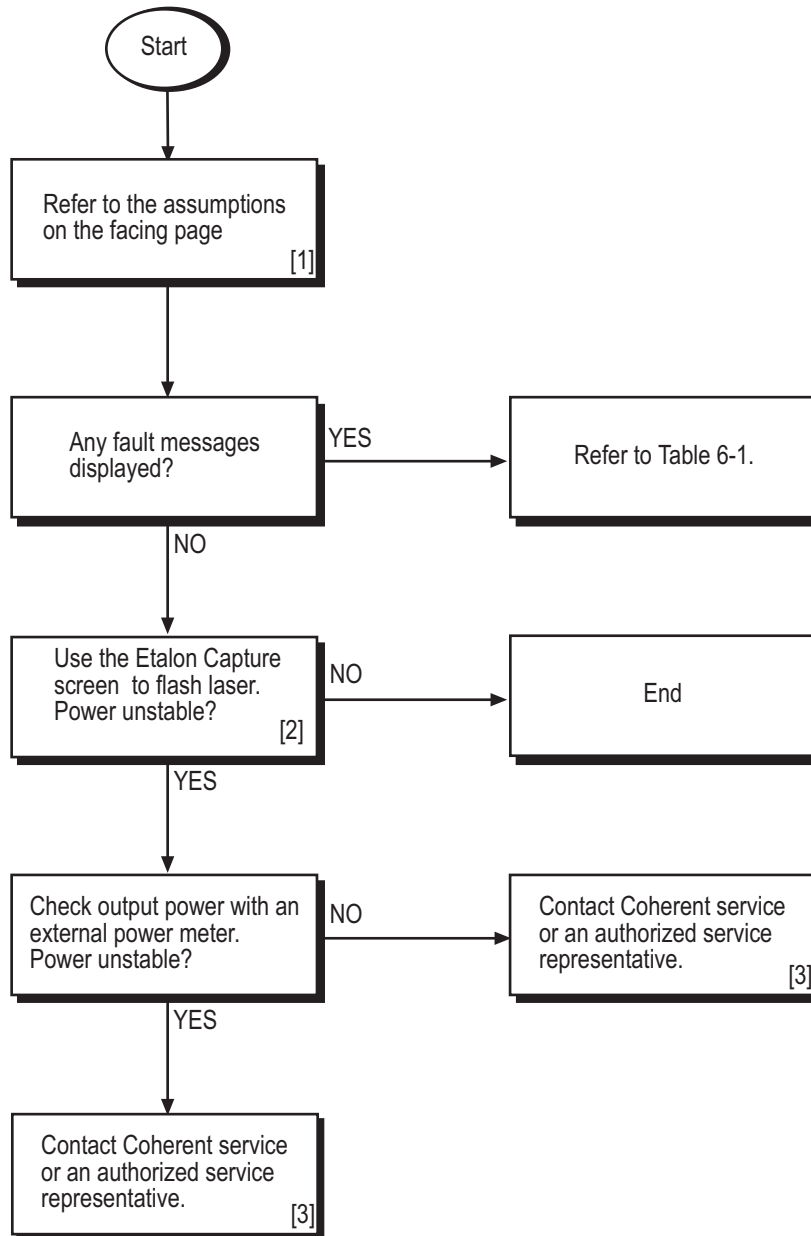
**[1]** ASSUMPTIONS:

- The laser system had been operating immediately prior to shutdown.
- The interlocks are closed as described in Section Three: Installation. The laser will not operate with an interlock circuit open.

If a user interlock is installed, the user interlock can be verified by temporarily replacing it with the interlock supplied with the system.

**[2]** If the laser system must be returned directly to Coherent, an RMA (Return Material Authorization) number is required. Contact Coherent or an authorized representative.

### Chart 3. Laser Output Unstable



### **Chart 3. Laser Output Unstable [Continued]**

**The numbered paragraphs below are keyed to supplement this flowchart.**

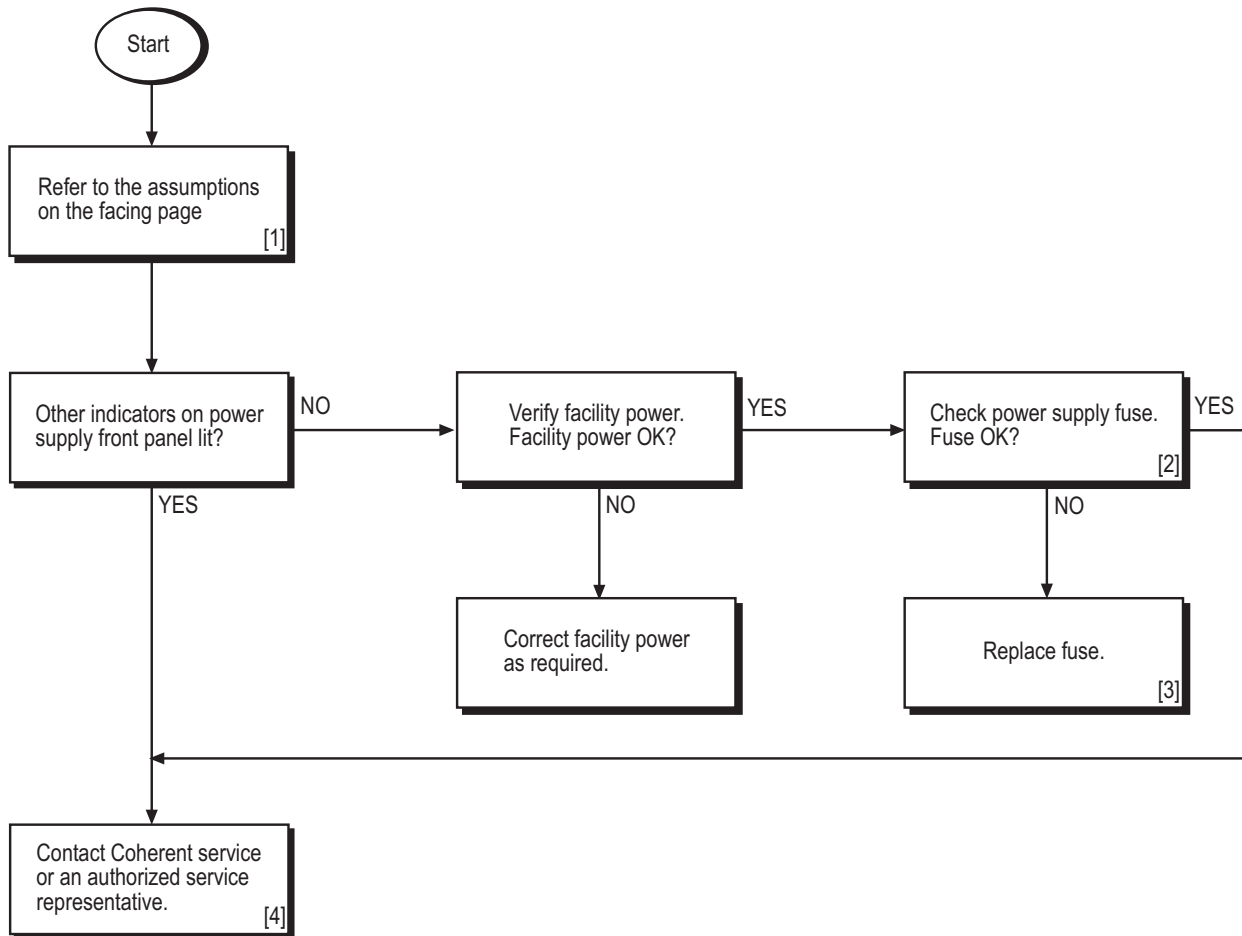
**[1]** ASSUMPTIONS:

- The laser system has been installed in accordance with the installation procedures in Section Three: Installation.

**[2]** Refer to Figure 4-4 on page 4-12 to access the Etalon Capture Screen. Press SELECT from within the screen to flash the laser.

**[3]** If the laser system must be returned directly to Coherent, an RMA (Return Material Authorization) number is required. Contact Coherent or an authorized representative.

### Chart 4. AC ON Indicator Does Not Light



## Chart 4. AC ON Indicator Does Not Light [Continued]

**The numbered paragraphs below are keyed to supplement this flowchart.**

- [1] ASSUMPTIONS:
- The laser system has been installed in accordance with the installation procedures in Section Three: Installation.
  - The power cord is connected to an active facility power source and the power switch on the power supply rear panel is on.
- [2] After performing the “Turn-off (Complete Shut-down)” on page 4-5”, disconnect the laser system from facility power and remove the fuse (Figure 4-3 on page 4-10, item 1) using the fuse replacement procedures located in this section. Verify continuity (closed circuit) between the two fuse terminals.
- [3] Refer to the fuse replacement procedures located in this section. If the fault persists, contact Coherent or an authorized representative.
- [4] If the laser system must be returned directly to Coherent, an RMA (Return Material Authorization) number is required. Contact Coherent or an authorized representative.

## **Chart 5. Head Laser Emission Lamp Fault**

**[1]** Press MENU EXIT to clear the fault display.

If the fault does not clear, a fault message will appear on the Main Display and on the Fault Status menu (Figure 4-4 on page 4-12).

If the fault clears, open the shutter and resume operation.

**[2]** Ensure the umbilical is not strained or cut and that bend radius of the optical fiber is five inches or greater.

**[3]** Turn the power switch on the power supply rear panel to the OFF position for approximately 20 seconds. Then turn the switch back to the “on” position.

**[4]** If the fault persists, contact Coherent or an authorized representative. If the laser system must be returned directly to Coherent, an RMA (Return Material Authorization) number is required. Contact Coherent or an authorized representative.

## Chart 6. External Interlock Fault

**The laser system will not operate with an open interlock circuit. Ensure the external interlock is supplied with the system or a user furnished interlock is installed. See paragraph titled, “External Interlock” on page 3-7 for more information on the external interlock.**

- [1]** Press MENU EXIT to clear the fault display.

If the fault does not clear, a fault message will appear on the Main Display and on the Fault Status menu (Figure 4-4 on page 4-12).

If the fault clears, open the shutter and resume operation.
- [2]** Ensure the EXTERNAL interlock connector on the power supply rear panel is firmly seated.
- [3]** If a user interlock is installed, turn the keyswitch to STANDBY and replace the user interlock circuit with the external interlock supplied with the system. If the fault clears, the user interlock circuit is defective.

If the fault does not clear, verify continuity of the interlock connector.

If the fault clears, open the shutter and resume operation.
- [4]** Turn the power switch on the power supply rear panel to OFF position for approximately 20 seconds. Then turn the switch back to the “on.”
- [5]** If the fault persists, contact Coherent or an authorized representative. If the laser system must be returned directly to Coherent, an RMA (Return Material Authorization) number is required. Contact Coherent or an authorized representative.

## Chart 7. PS Interlock Fault

**To ensure the top cover of the power supply is secure, turn the keyswitch to the STANDBY position and verify the power supply top cover is closed with all fasteners fully tightened.**

**[1]** Press MENU EXIT to clear the fault display.

If the fault does not clear, a fault message indication will appear on the Main Display and on the Fault Status menu (Figure 4-4 on page 4-12).

If the fault clears, open the shutter and resume operation.

**[2]** Turn the power switch on the power supply rear panel to OFF position for approximately 20 seconds. Then turn the switch back to the "on."

**[3]** If the fault persists, contact Coherent or an authorized representative. If the laser system must be returned directly to Coherent, an RMA (Return Material Authorization) number is required. Contact Coherent or an authorized representative.



**Chart 8. LBO Temperature Fault  
Vanadate Temperature Fault  
Etalon Temperature Fault  
Diode 1 Temperature Fault**

**[1]** Press MENU EXIT to clear the fault display.

If the fault does not clear, a fault message will appear on the Main Display and on the Fault Status menu (Figure 4-4 on page 4-12).

If the fault clears, open the shutter and resume operation.

**[2]** Verify the set points in the “Temperature Set Points” submenu are the same as on the test sheet. If a diode or LBO optimization has been performed, verify their temps are the same from the last optimization. If different, contact Coherent or an authorized representative.

**[3]** Turn the power switch on the power supply rear panel to OFF position for approximately 20 seconds. Then turn the switch back to the “on.”

**[4]** If the fault persists, contact Coherent or an authorized representative. If the laser system must be returned directly to Coherent, an RMA (Return Material Authorization) number is required. Contact Coherent or an authorized representative.

## Chart 9. Baseplate Temperature Fault

- [1]** Press MENU EXIT to clear the fault display.

If the fault does not clear, a fault message will appear on the Main Display and on the Fault Status menu (Figure 4-4 on page 4-12).

If the fault clears, open the shutter and resume operation.

- [2]** Verify the laser head is installed on a riser/heat sink and the riser/heat sink is located on a surface that will dissipate heat at a rate that will maintain the baseplate temperature below 55°C.

Ensure that the ambient temperature is not excessively high and the laser head is not located near a heat generating source.

If a suitable ambient temperature cannot be maintained or if the laser head must be located in a less than optimum location, an optional water cooled riser/heat sink is available from Coherent.

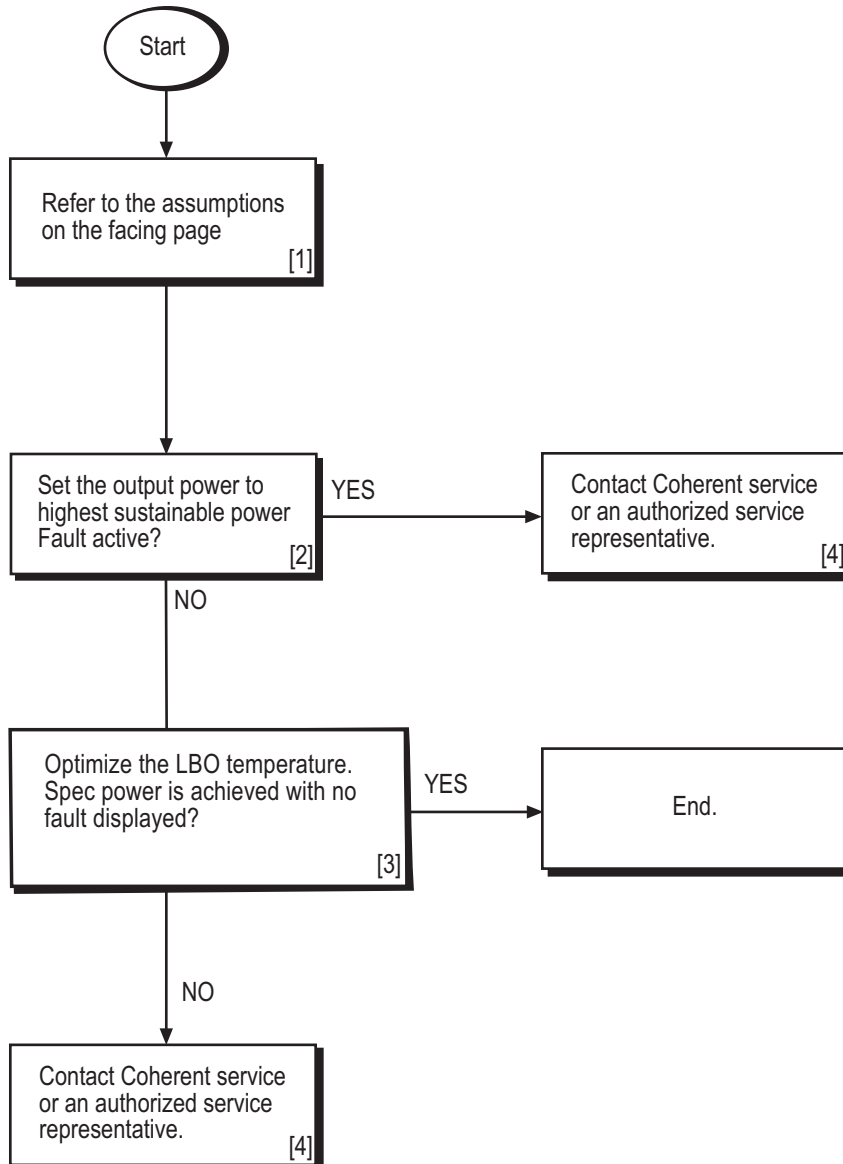
- [3]** Turn the power switch on the power supply rear panel to OFF position for approximately 20 seconds. Then turn the switch back to the "on."

- [4]** If the fault persists (and the ambient temperature and laser head location meet the above requirements), contact Coherent or an authorized representative. If the laser system must be returned directly to Coherent, an RMA (Return Material Authorization) number is required. Contact Coherent or an authorized representative.

## **Chart 10. Diode Heat Sink Temperature Fault**

- [1]** Press MENU EXIT to clear the fault display.  
Turn the keyswitch on the power supply front panel to STANDBY.
- [2]** Verify the following conditions are true:
  - The cooling fans are not obstructed
  - The rear, top, and left side of the power supply are not obstructed
  - The air filter is not clogged (do not remove the air filter when the fans are rotating)
  - The power supply is not located near a heat source
  - The ambient temperature is not excessively high
- [3]** Turn the power switch on the power supply rear panel to OFF position for approximately 20 seconds. Then turn the switch back to the “on.”
- [4]** If the fault persists (and the ambient temperature and power supply location meet the above requirements), contact Coherent or an authorized representative. If the laser system must be returned directly to Coherent, an RMA (Return Material Authorization) number is required. Contact Coherent or an authorized representative.

# Chart 11. Diode Over Current Fault Over Current Fault 10% Current Increase (No Fault)



**Chart 11. Diode Over Current Fault [Continued]  
Over Current Fault  
10% Current Increase (No Fault)**

- |   |
|---|
| <p><b>[1]</b> ASSUMPTIONS:</p> <ul style="list-style-type: none"><li>• The laser system has been installed in accordance with the installation procedures in Section Three: Installation.</li></ul> |
| <p><b>[2]</b> If the fault is displayed, press EXIT to clear the fault.</p>   |
| <p><b>[3]</b> Use the LBO Optimization menu shown in Figure 4-4 on page 4-12 to perform the optimization routine.</p>   |
| <p><b>[4]</b> If the laser system must be returned directly to Coherent, an RMA (Return Material Authorization) number is required. Contact Coherent or an authorized representative.</p>           |

**Chart 12. Diode Under Voltage Fault  
Diode Over Voltage Fault  
Diode EEPROM Fault  
LBO Not Locked at Set Temperature  
Laser Head EEPROM Fault  
Power Supply EEPROM Fault  
Power Supply-Head Mismatch Fault  
Shutter State Mismatch  
Head-Diode Mismatch Fault**

- [1] To clear a fault, the power supply keyswitch should be turned to the STANDBY position, and the EXIT push button pressed. If the fault condition no longer exists, exiting the Fault Status screen will clear the fault. Once the keyswitch is turned to the ON position, laser operation returns to the state it was in before the fault occurred except the shutter will be closed. If the fault condition still exists, the system message "FAULT ACTIVE" will be displayed in the Main Display screen.

If the fault does not clear, a fault message will continue to appear on the Fault Status menu (Figure 4-4 on page 4-12).

If the fault clears, open the shutter and resume operation.

Note: it may be necessary to wait for the LBO crystal to lock at the set temperature before resuming operation.

- [2] Turn the power switch on the power supply rear panel to OFF position for approximately 20 seconds. Then turn the switch back to the "on."
- [3] If the fault persists, contact Coherent or an authorized representative. If the laser system must be returned directly to Coherent, an RMA (Return Material Authorization) number is required. Contact Coherent or an authorized representative.

## **Chart 13. Battery Requires Service**

- [1]** To clear a fault, press the MENU EXIT pushbutton and perform the complete shutdown. Wait at least five seconds before turning the system on. Upon turn-on, verify the status of the system.

If the fault clears, open the shutter and resume operation.

Note: it may be necessary to wait for the LBO crystal to lock at the set temperature before resuming operation.

- [2]** If the fault persists, perform the procedure in paragraph titled, “Battery Replacement” on page 6-42. If the fault still persists after replacing the battery, the laser system must be returned to Coherent. A Return Material Authorization (RMA) number is required. Contact Coherent or an authorized representative for more information or to receive an RMA number.

## FAP-I Replacement

Refer to Table 6-1 for the troubleshooting charts prior to replacing the FAP-I. Contact Coherent technical support or a local service representative to assist in determining the need for FAP-I replacement.

### Preliminary Steps and Data

1. With the laser system in STANDBY, record the following system parameters from the "Temperature Set Points" submenu:
  - a. LBO temperature set point
  - b. Vanadate temperature set points
  - c. Etalon temperature set point
  - d. FAP-I temperature set point
2. Perform the "Turn-off (Complete Shut-down)" on page 4-5. The associated cool-down cycle takes approximately 30 minutes. The front panel display indicates when the cool-down cycle is complete.



---

**Do not turn the power switch on the rear panel to the OFF position or disconnect the AC power input until the cool-down cycle is complete.**

---

3. When the LBO cool-down cycle is complete, turn the power switch on the power supply rear panel to the OFF position.



---

**Do not disconnect the power cord from facility power. The power supply chassis must be grounded either by the power cord or a separate ground to avoid electro-static discharge (ESD).**

---

4. Remove the top cover of the power supply.



---

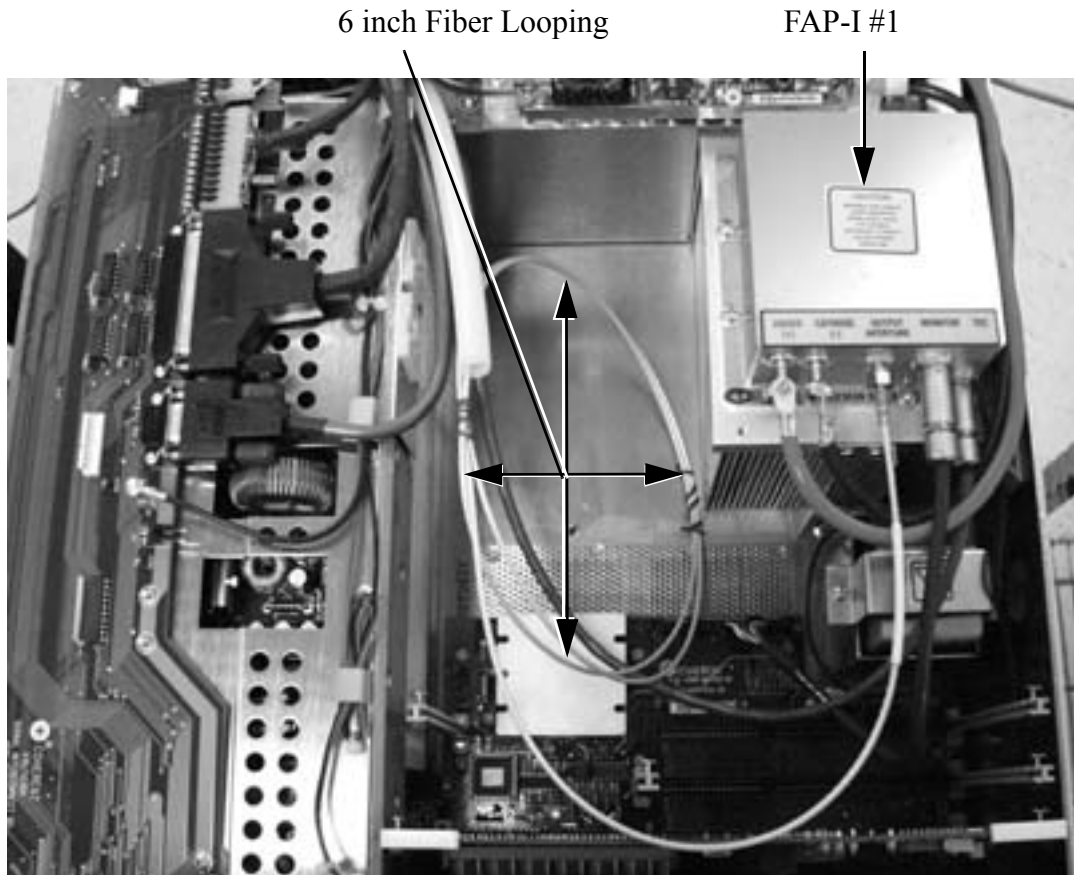
**The FAP-I can be damaged by electro-static discharge (ESD). To avoid ESD, a personal grounding strap must be used at all times.**

---



## FAP-I Handling Precautions

1. The FAP-I can be damaged by improper ESD handling. To avoid ESD, a personal grounding strap must be used at all times. Follow the instructions that accompany the personal grounding strap.



*Figure 6-1. Location of FAP-I Assemblies and Fiber Looping*

2. A shorting clip (Figure 6-2) must be installed between the anode and cathode terminals to avoid inadvertent ESD before the leads are disconnected from the terminals.
3. When disconnecting the fiber optic cable from the FAP-I assembly, a cap (Figure 6-2) must be installed over both the FAP-I optical emission port and the end of the fiber optic cable to protect them from accidental damage or contamination.



*Figure 6-2. Fiber Optic Covers and FAP-I Anode/Cathode Shorting Clip*



---

**The end of the fiber optic cable is an optical surface. Do not allow the end of the fiber optic cable to make contact with any surface, including the fingers.**

**A contaminated optical surface can cause system damage. To minimize exposure to contaminants, the blue protective plastic cap must be installed whenever the fiber is disconnected.**

**When removing or installing the fiber optic cable, do not allow the fiber optic cable to rotate while loosening the ferrule connector.**

---

## **Fiber Cable Handling Precautions**

1. When removing or installing a fiber optic cable, do not allow the fiber optic cable to rotate while loosening the ferrule connector (Figure 6-4).
2. The end of the fiber optic cable is an optical surface. Do not allow the end of the fiber optic cable to contact any surface, including the fingers. To minimize exposure to the environment, the protective plastic cap must be left in place until a

connection is made and immediately installed over the fiber end when a connection is disassembled.

3. Do not allow the end of the fiber optic cable to contact the diode (FAP-I) assembly or any other surface including the fingers. Failure to do so can damage the optical surface.



---

**Inspect the fiber optical surface to verify the cleaning procedure is necessary.**

---

4. Do not install a contaminated or damaged fiber optic cable to the FAP-I. Doing so will cause a failure of the laser system. Contamination or damage can be difficult to detect. A magnifying glass may help during the inspection



---

**Do not use acetone as a cleaning solvent on fiber optical surfaces. It will dissolve the matrix that supports the fiber and will destroy the optical transport fiber permanently.**

---

5. The end of the fiber optic cable should be cleaned using the “Drop and Drag” procedure. Refer to the paragraph titled, “LBO Temperature Optimization” on page 6-40. Do not use any other procedure or method. If scratches or other damage is present, the FAP-I replacement should be terminated and the plastic cap reinstalled. Contact Coherent or an authorized local representative.
6. Excessively tight fiber umbilical bends (less than a 3-inch radius) can cause permanent damage to the transport fiber.

## FAP-I Removal

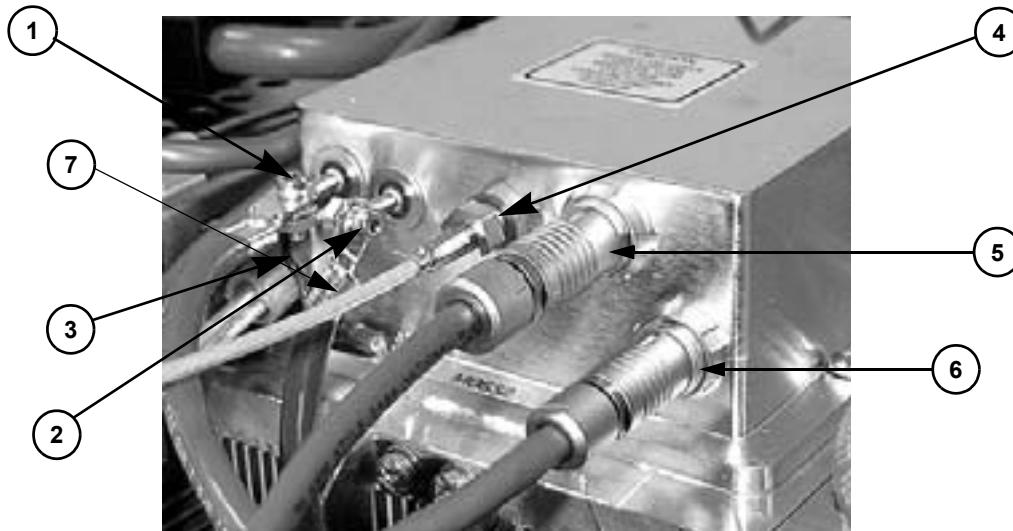
1. Install shorting clip (Figure 6-2) between anode and cathode of FAP-I assembly to be removed. Disconnect the anode and cathode connectors, see Figure 6-3.
2. Disconnect the Case/Anode ground jumper from the FAP-I assembly.



---

**Wear finger cots (supplied with the replacement FAP-I) while handling the fiber optic cable.**

---



- |   |  |
|---|--|
| 1. Anode Connector Terminal                           | 5. Personality Module, Thermistors,<br>Diode Hours Connector |
| 2. Cathode Connector Terminal                         | 6. TEC Coolers Inputs/Outputs Connector                      |
| 3. Case/Anode Ground Jumper                           | 7. Fiber Optic Cable   |
| 4. Fiber Optic Connector and Optical<br>Emission Port |  |

**Figure 6-3. FAP-I Assembly Interface**

3. Disconnect the fiber optic cable as follows:
  - a. While firmly holding the fiber optic cable, loosen the ferrule connector securing the fiber optic cable to the FAP-I. It may be necessary to use a small wrench to loosen the connector.
  - b. Note the ferrule cutout (see Figure 6-4). Carefully extract the fiber optic cable from the FAP-I and remove the ferrule.
  - c. Immediately install the two plastic protective caps, one over the end of the fiber cable and the second over the FAP-I optical output port (Figure 6-2).
4. Disconnect the Personality module and TEC connectors from the FAP-I assemblies by pulling back on the outer sleeve and then unplugging the connector.
5. Remove the eight screws securing the FAP-I to the heat sink (two on each side).

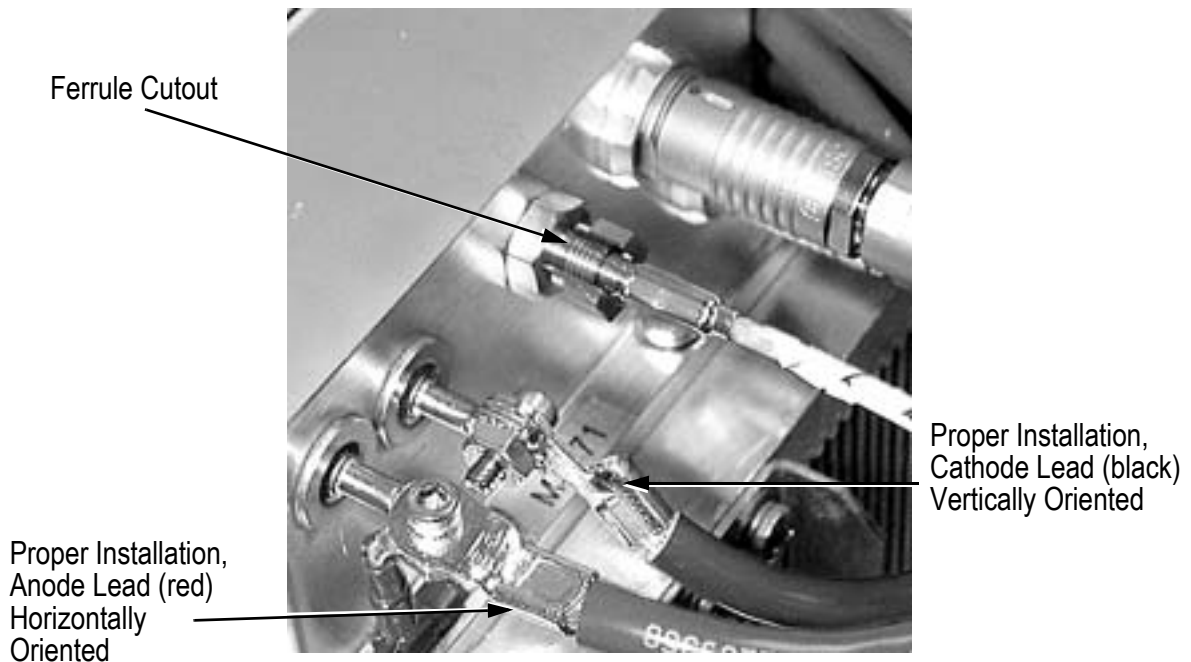


---

**Due to the thermal grease on the bottom of the FAP-I assembly, it may be necessary to work the old assembly loose by rotating (wiggling) it back and forth around its center.**

---

6. Remove the FAP-I from the power supply and clean the thermal grease from the FAP-I and the mounting surface (alcohol works well for this).



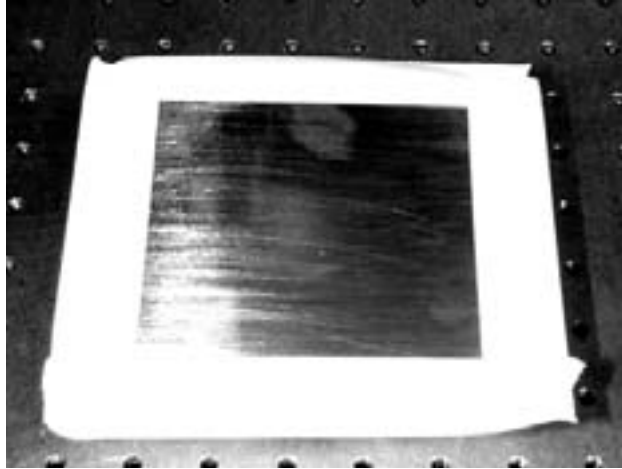
*Figure 6-4. FAP-I Fiber Optic Connector*

## **FAP-I Installation**

The following items are included in the FAP-I installation kit:

- FAP-I assembly
- Die-cut plastic masking sticker
- Tube of thermal compound
- Plastic spatula for spreading thermal compound
- Fiber optic cap
- Finger cot for fiber handling

1. Remove the new FAP-I from the shipping container. Leave the shorting clip and protective plastic cap in place to avoid possible ESD and contamination damage.
2. Apply the die-cut template to the bottom of the diode to avoid contaminating the screw holes with thermal compound in the next step. Alternatively, place masking tape over the edges of the FAP-I baseplate as illustrated in Figure 6-5.
3. Using the plastic applicator, apply an even coating of thermal grease to the bottom of the FAP-I. The thickness of the grease film should be less than the thickness of the masking tape or template.
4. Remove the template or masking tape.
5. Position the FAP-I assembly on the heat sink.
6. Re-attach the Case/Anode ground jumper to the FAP-I baseplate.
7. Secure the FAP-I to the heat sink using the remaining seven mounting screws.
8. Remove any excess thermal grease from around the assembly.



*Figure 6-5. Preparation of the Replacement FAP-I Assembly*



---

**After connection, the red anode lead should be horizontally oriented and the black cathode lead should be vertically oriented. This is illustrated in Figure 6-4 and minimizes the potential of generating/picking up EM noise.**

---

9. Re-connect the anode and cathode leads. Be sure to reconnect the case/anode ground jumper when connecting the anode lead.
10. Remove the anode/cathode shorting clip.
11. Re-connect the Personality module and TEC connectors.
12. Inspect, and, if necessary, clean the fiber optic surface. (See the procedure titled “LBO Temperature Optimization” below).
13. Re-connect the fiber optic cable to the FAP-I, securing the nut finger-tight (no more than 4 in-lbs. if using a torque wrench).
14. If disconnected, re-connect the AC power cord to facility power. If a ground wire was used, remove it.
15. Replace the power supply cover and perform the procedure in paragraph titled, “Turn-on (Cold-Start)” on page 4-2.
16. Verify system parameters.

## **Fiber Optic Cleaning**

Before performing the cleaning procedure, inspect the fiber optic surface with a fiberscope or magnifier to determine the extent to which the fiber might be damaged or contaminated. Only perform the cleaning procedure if the fiber optic surface shows imperfections, otherwise the procedure may introduce dust, dirt, or potentially induce damage to the fiber optic. Reference the figures titled “Good Fiber” on page 6-38, “Bad or Questionable Fibers” on page 6-38, and “Guidelines for Fiber Optic Inspection” on page 6-39 to determine if the fiber requires cleaning and/or replacement.

The Drop and Drag method is the least abrasive cleaning method and should always be used first to remove imperfections on the fiber optic surface. If the Drop and Drag method will not remove particulates, then the fiber optic surface should be cleaned with a cleanroom swab. The cleanroom swab is most effective; however, a lens tissue with a hemostat may be used as an alternative to the cleanroom swab.

## Equipment Needed

The following materials are required to perform this procedure:

- Lens cleaning tissue
- Cleanroom-quality swabs (Coherent recommends using Micro Alpha Swab ESD, Part #1488-758E from Cintas at (800) 786-6027)

Lens tissue and a hemostat may be used as an alternative to the swabs.

- Fresh spectroscopic-grade Methanol
- Fiber microscope (fiberscope), 200X total magnification
- Non-powdered, non-coated Latex (or equivalent) gloves or fingercots



---

**Important: Do not use Acetone! Acetone will dissolve adhesives used in the manufacture of the fiber optic and will destroy the fiber optic cable.**

---

## Fiberscope

A recommended cost-effective fiberscope is the OFS 300-200C model with 20X eyepiece and SMA adapter manufactured by Noyes™. See Figure 6-6.

## Procedure

Always wear latex gloves or fingercots (or the equivalent) while performing any of the following procedures. Fingerprints, dust, condensation, and oils from the hand can damage the fiber optic surface.

## Drop and Drag Procedure

1. Using a medicine dropper and a new, clean lens tissue, put one drop of Methanol near the center of the lens tissue. See Figure 6-7.
2. Holding the fiber vertically so the fiber surface points to the ceiling, carefully place the tissue so the optical surface rubs against the underside of the tissue. See Figure 6-8.
3. In a single movement, gently drag the fiber surface against the underside of the wet tissue in a circle, spiraling out, taking care not to go over the same part of the tissue twice. See Figure 6-9.

Drag the fiber out from the saturated part of the tissue to the dry parts of the tissue, which dries the fiber optic surface and prevents Methanol residue.





**Figure 6-6. Fiberscope with 20X Eyepiece and SMA Adapter**

4. Re-check the fiber with the fiberscope.

If the fiber surface is now ideal or complies with the acceptable guidelines as illustrated in Figure 6-19 on page 6-39, immediately install the fiber optic into the FAP-I/FAP-B.

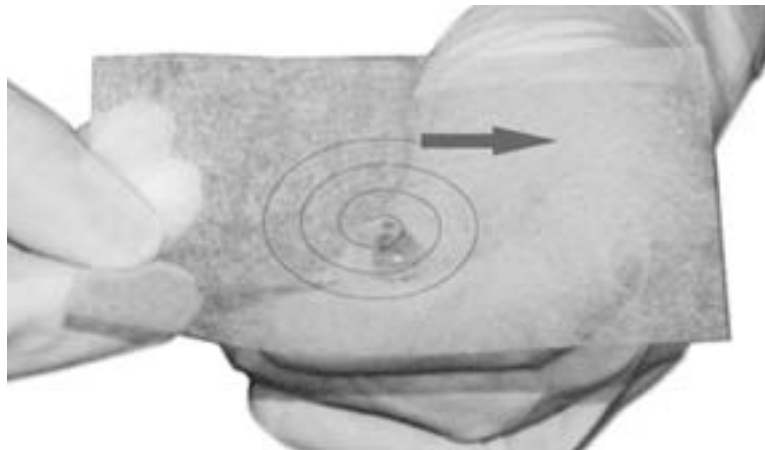
If the imperfections have not been removed, or if any Methanol residue has been induced (See Figure 6-10), continue with the cleanroom swab procedure below.



**Figure 6-7. Methanol Drop on Lens Tissue**



*Figure 6-8. Placement of the Fiber Optic Against the Lens Tissue*



*Figure 6-9. Movement of Fiber Optic Against Lens Tissue*



---

**Methanol residue can cause burn spots or potentially catastrophic damage to the fiber optic and the FAP-I/FAP-B. See Figure 6-10 for an illustration of Methanol residue.**

---



*Figure 6-10. Methanol Residue*

### Cleanroom Swab Procedure

Using lens tissue and a hemostat may be substituted for the cleanroom swab procedure. Reference the procedure titled “Alternative Cleaning Procedure” on page 6-35 for the alternate method.

1. Using a medicine dropper, put one to two drops of Methanol on the swab (Figure 6-11).
2. Vigorously shake off excess Methanol from the swab to prevent Methanol residue.



---

**Only the synthetic cloth should make contact with the fiber optic surface. Do not allow the plastic applicator to touch the fiber surface.**

---

3. Holding the fiber vertically so the fiber surface points to the ceiling, carefully place the base of the swab against the fiber optic surface, taking care not to touch the plastic applicator to the fiber optic surface. See Figure 6-12.
4. Drag the swab across the fiber optic surface in a single stroke. **Do not** drag the swab back and forth.
5. Repeat Step 4 using the other side of the swab.



**Figure 6-11. Methanol Drop**



**Figure 6-12. Placement and Movement of the Swab Against the Fiber Optic Surface**

6. Re-check the fiber using the fiberscope.  
If the fiber surface is now ideal or complies with the acceptable guidelines as illustrated in Figure 6-19 on page 6-39, immediately install the fiber optic into the FAP-I/FAP-B.  
If imperfections remain, repeat the procedure using a new swab.
7. If imperfections still remain, compare the image in the fiberscope with Figure 6-19 on page 6-39 and determine whether the fiber optic must be replaced. Contact Coherent Service if further guidance is needed.

**Alternative Cleaning Procedure**

As an alternative to the cleanroom swab procedure, use the following procedure with lens tissue and a hemostat:

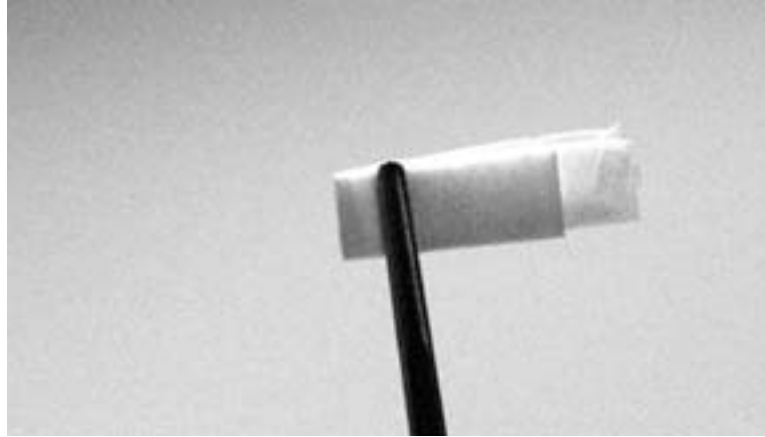
1. With one hand on each end of the lens tissue, fold the tissue in half (width wise), three times. Do not touch any part of the lens tissue that will make contact with the fiber optic surface. See Figure 6-13.
2. Use a hemostat to fold the tissue in half, lengthwise. Do not touch any part of the lens tissue that will be used to clean the fiber optic surface. See Figure 6-14.
3. Attach a hemostat to the lens tissue as shown in Figure 6-15.



*Figure 6-13. Folded Lens Tissue (Width Wise)*



*Figure 6-14. Folded Lens Tissue (Lengthwise)*



**Figure 6-15. Hemostat Attached to Properly Folded Lens Tissue**

4. Using a medicine dropper, put two drops of Methanol on the lens tissue.
5. Vigorously shake off excess Methanol from the folded tissue to prevent Methanol residue.



---

**Only the lens tissue should make contact with the fiber optic surface. Do not allow the hemostat to touch the fiber surface.**

---

6. Holding the fiber vertically so the lens surface points to the ceiling, carefully place the base of the wet side of the folded tissue against the fiber optic surface, taking care not to touch the fiber optic with the hemostat. See Figure 6-16.
7. Drag the folded tissue across the fiber optic surface in a single stroke. **Do not** drag the swab back and forth.
8. Repeat Step 7 using the other side of the folded tissue.
9. Re-check the fiber using the fiberscope. If imperfections remain, repeat the procedure using a new lens tissue.
10. If imperfections still remain, compare the image in the fiberscope with Figure 6-19 and determine whether the fiber optic must be replaced. Contact Coherent Service if further guidance is needed.

If the fiber surface is now ideal or complies with the guidelines as illustrated in Figure 6-19 on page 6-39, immediately install the fiber optic into the FAP-I/FAP-B.



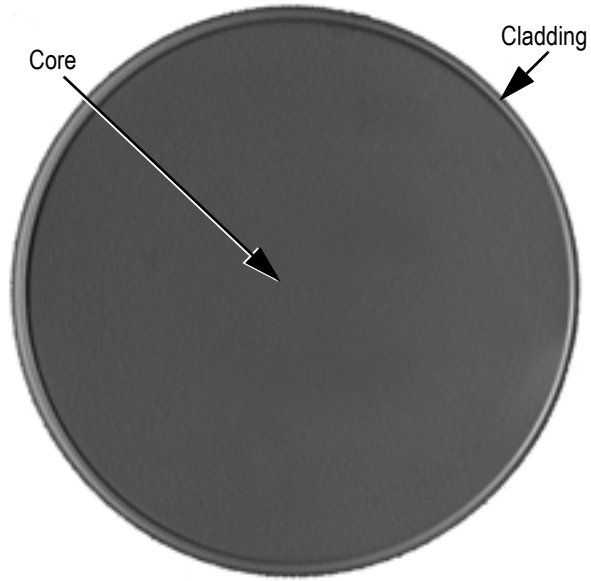
*Figure 6-16. Placement and Movement of the Folded Tissue Against the Fiber Optic Surface*

### **Examples of Good and Bad Fibers**

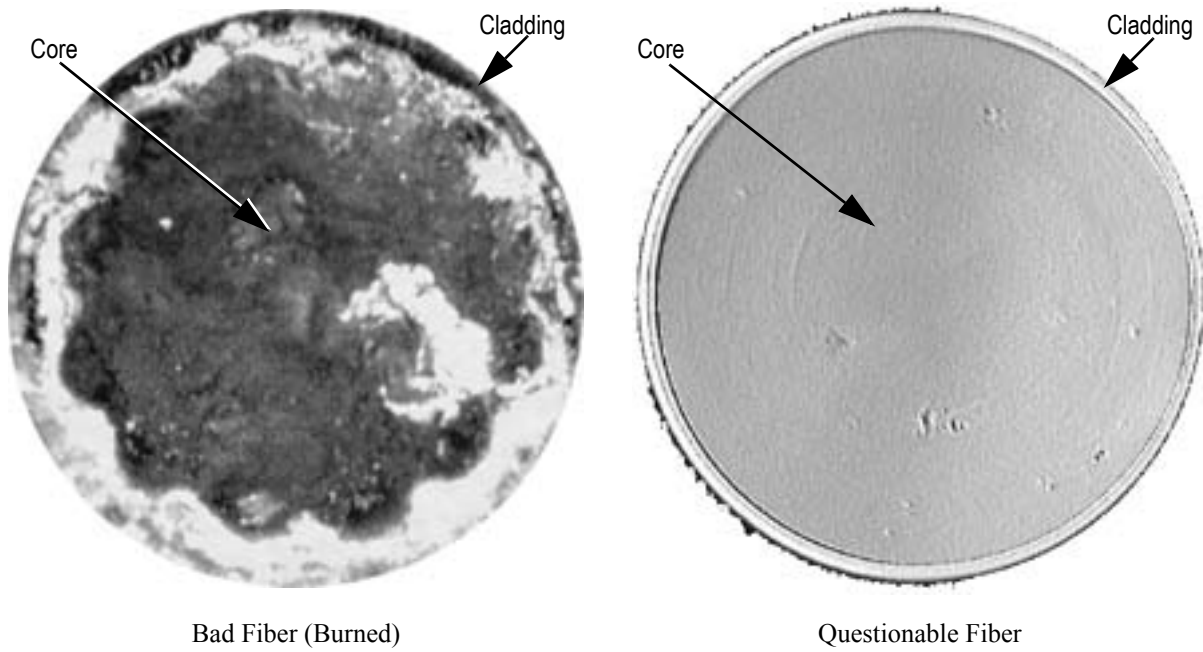
Figure 6-17 shows an image of the ideal fiber optic surface that can be used successfully in the FAP-I/FAP-B assembly through a fiberscope. Figure 6-18 shows images of fibers through a fiberscope with imperfections that can impair the function of the assembly. The image on the left is clearly a damaged fiber. Severely damaged fibers must not be used in the FAP-I/FAP-B assembly or permanent and severe damage to the assembly will occur.

The image on the right shows a fiber that is questionable. If the power output is acceptable, then the fiber can be used with little concern for damaging the assembly. However, if the power output is unstable or not up to acceptable standards, the fiber must be considered damaged and must not be used.

Figure 6-19 illustrates further criteria for accepting or rejecting a fiber because of damage. Note that the views shown do not represent the entire surface of the fiber optic. Much of the surface is the metal connector and only the 800-micron core is the actual optical fiber.

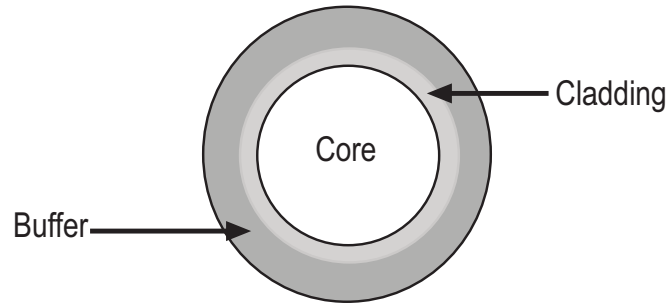


**Figure 6-17. Good Fiber**

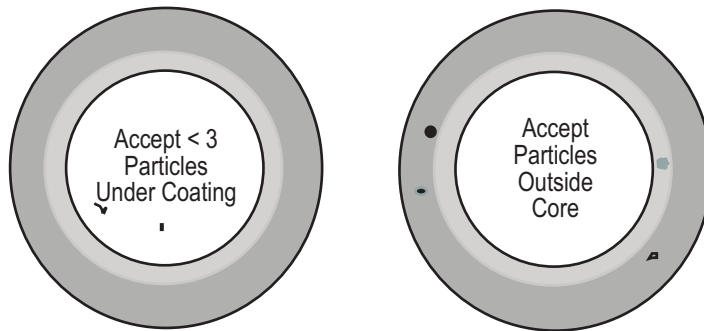


**Figure 6-18. Bad or Questionable Fibers**

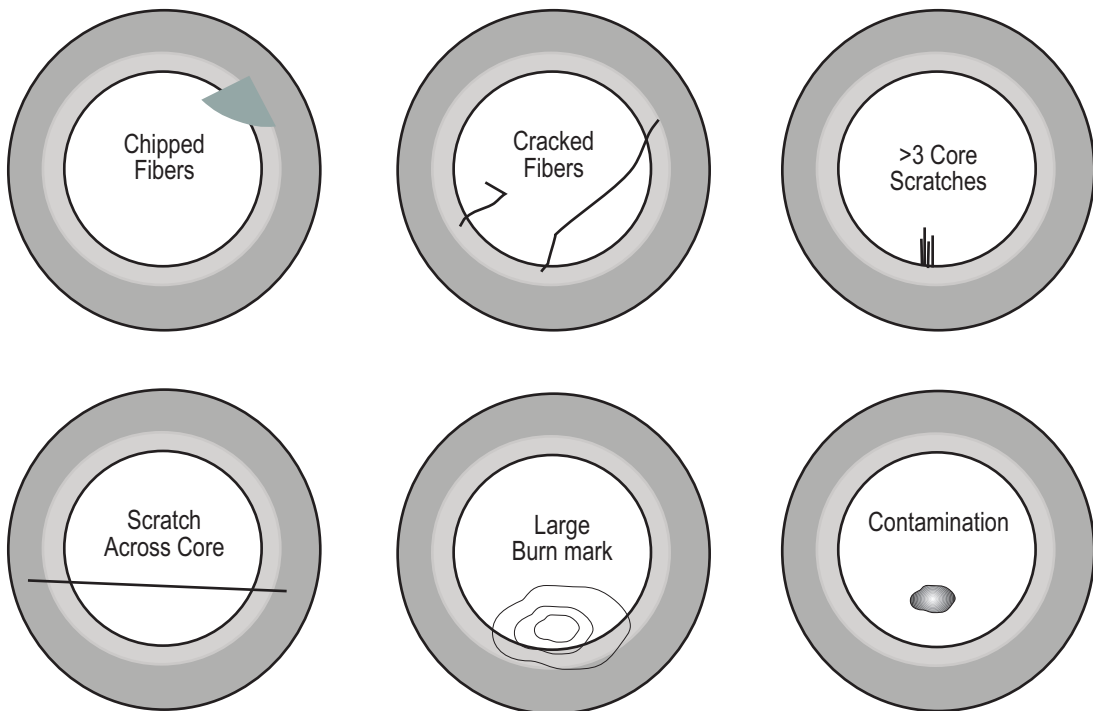




**IDEAL FIBER**



**ACCEPTABLE IMPERFECTIONS**



**CRITERIA FOR REJECTION**

**Figure 6-19. Guidelines for Fiber Optic Inspection**

## LBO Temperature Optimization

The conversion efficiency of the LBO frequency doubler is heavily dependent upon temperature. A temperature change of 1°C can reduce the doubling efficiency by more than 50%. To compensate for the reduced efficiency, the laser will use more current to produce the desired 532 nm output. This will reduce the lifetime of the diodes.

As a solution to this potential problem, the Verdi V-2/V-5/V-6 software contains a menu routine which will perform a LBO temperature optimization automatically to maximize the conversion efficiency of the doubler. The LBO Optimization routine should run when diode current is observed to be 10% greater than baseline values.



---

**Note that the shutter is active during the LBO optimization. Because laser power will change while the routine executes, Coherent recommends the shutter remains closed throughout the process.**

---

To find an accurate LBO setpoint temperature, set the output power level as close to maximum power (depending on system type) as possible. The routine is designed such that it will not run if the laser power level is less than 80% of the specified maximum power.

Once the routine is complete, the system will display “LBO optimized” and return the laser to “Light Regulation” mode at the preset power level.

## Performing the Optimization

1. Turn the Verdi on at the maximum power level. Record the LBO setpoint temperature.
2. Scroll to the LBO Optimization submenu and select the LBO optimization routine. LBO optimization requires up to 45 minutes to run.
3. Once the routine is complete, record the LBO temperature as the new baseline value in the system weekly log book.

During optimization, the LBO temperature will increase and decrease with the software recording the Verdi output power at each LBO temperature. (This routine is performed with a constant diode current.)

Optimum LBO temperature will be determined based on the Verdi Output Power vs. LBO Temperature curve. The new temperature will be stored as the LBO temperature set point.

## LBO Error Message

If the system is not able to determine an optimum LBO temperature the message “TLBO < 2°C Temperature not changed” will be displayed. If this should occur, contact your local Coherent Service representative.

## Fuse Replacement



### Criteria for Replacement

Defective fuse per troubleshooting Charts 1 and 4.

---

**Do not turn the power switch on the rear panel to the OFF position or disconnect the AC power input until the LBO cool down cycle is complete.**

---

1. Perform the procedure in paragraph titled, “Turn-off (Complete Shut-down)” on page 4-5. The associated cool-down cycle will take approximately 30 minutes. The front panel display will indicate when the cool-down cycle is complete.
2. Turn the power switch on the power supply rear panel to the OFF position and disconnect the power cord from facility power.



---

**A fuse that fails repeatedly is an indication of a more serious problem. In this case, the system should be returned to the factory. If the laser system or components are being returned directly to Coherent, an RMA (Return Material Authorization) number is required. Contact Coherent or an authorized representative.**

---

3. The location of the fuse is shown on Figure 4-2 on page 4-8. Insert a small straight-slotted screwdriver and twist counter-clockwise to remove the fuse holder.
4. Replace the fuse with an appropriate fuse and reinstall the fuse holder.
5. Connect the power supply power cord to facility power.
6. Perform the procedure in paragraph titled, “Turn-on (Cold-Start)” on page 4-2.

### Verification of Successful Installation

7. The AC ON indicator on the power supply front panel will light.

## Battery Replacement

The backup battery in the laser system power supply must be replaced as soon as possible after the fault message "Battery Requires Service" is displayed on the power supply front panel. Failure to do so may result in damage to the system when coupled with a loss in AC power.



---

**Do not turn the power switch on the rear panel to the OFF position or disconnect the AC power input until the LBO cool down cycle is complete.**

---



---

**With AC power off, the power supply must be plugged in at least every 6 months to allow the battery to charge. Otherwise, permanent charging capacity loss may occur.**

---

## Preliminary Steps and Data

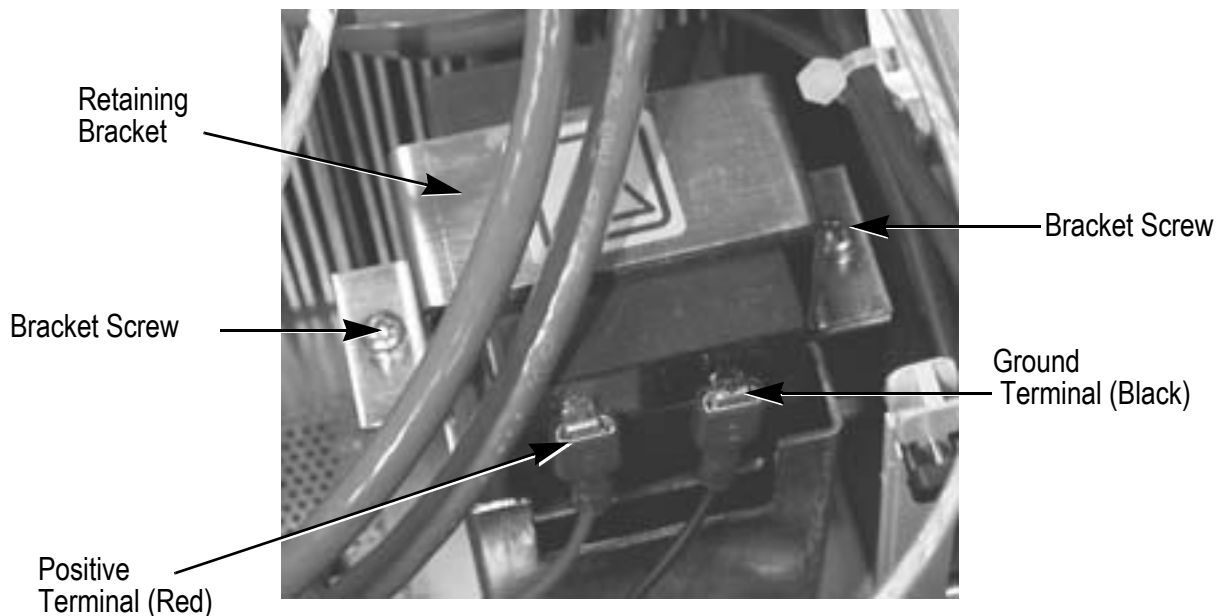
1. With the keyswitch set to the ON position and the system in "Light Control" operation, set the laser to its specification output power.
2. Record the following system data from the Temperature Set Points submenu. See menu titled, "Temperature Set Points" on page 4-15:
  - a. LBO temperature set point
  - b. Vanadate temperature set point
  - c. Etalon temperature set point
  - d. Diode #1 temperature set point
3. Record the following system data from the Diode Parameters Screen submenu. See menu titled, "Diode Parameters Screen" on page 4-16
  - a. Diode #1 current (software value).
4. Perform the procedure titled, "Turn-off (Complete Shut-down)" on page 4-5. The associated cool-down cycle

will take approximately 45 minutes. The front panel display will indicate when the cool-down cycle is complete.

5. After the LBO cool down cycle is complete, turn the power switch on the power supply rear panel to the OFF position and disconnect the power cord from facility power.

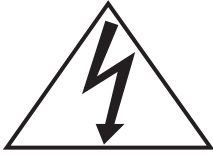
## Battery Removal and Installation

1. Using an Allen wrench, Remove the top cover of the power supply. The Verdi backup battery is located towards the front right hand corner of the Verdi power supply (with respect to the power supply front panel display). See Figure 6-20.
2. Remove the two Phillips-head screws that secure the battery retaining bracket in place, see Figure 6-20, and remove the bracket.
3. Unplug the ground (black) wire and then the positive (red) wire.
4. Remove the depleted battery and install the replacement.
5. The positive connection should be made before the ground wire is connected.
6. Re-install the battery retaining bracket.
7. Re-connect the laser system to the facility power.



**Figure 6-20. Power Supply Backup Battery**

8. Perform the procedure in paragraph titled, "Turn-on (Cold-Start)" on page 4-2.



---

**The charge on the backup battery can be determined by connecting a digital volt meter (DVM) across the terminals. Power to the laser system (switch on back panel) should always be OFF when checking battery charge. A fully charged battery should read between 12 and 13.4 V.**

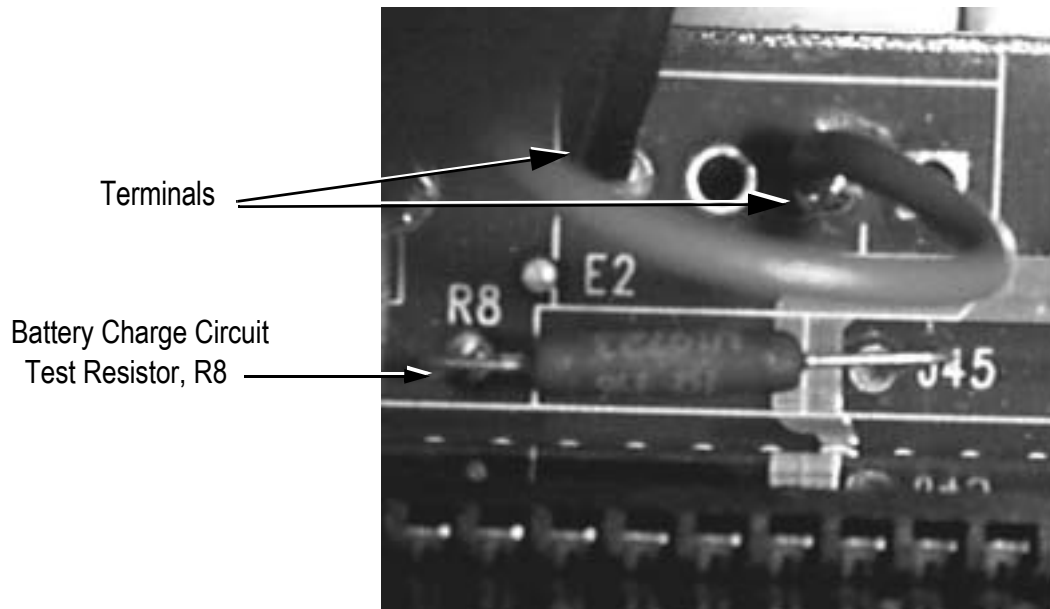
---

### **Battery Charge Circuit Verification**

1. Attach a DVM across R8 on the mother board (see Figure 6-21). Note that the polarity of the hookup is not important.
2. Turn the power supply rear panel switch to the ON position. The meter should start reading at 245 mV and begin counting down. The voltage (and speed) to which the meter counts down will depend on the initial charge state of the battery, see Table 6-2.
3. After the power to the laser system is enabled and the charge voltage across R8 has stabilized, the voltage across the battery terminals should read between 13 V and 14.6 V.

**Table 6-2. Battery Charge Circuit Voltages**

<b>BATTERY STATE</b>	<b>BATTERY VOLTAGE</b>	<b>CHARGE CIRCUIT VOLTAGE</b>
Very Low	9 V to 11 V	245 mV
Low	11 V to 12 V	245 mV to 200 mV
Moderate	12 V to 13 V	160 mV to 100 mV
Fully Charged	13 V to 13.4 V	60 mV to 10 mV
Over Charged	Over 13.4 V	0 mV



*Figure 6-21. Location of Battery Charge Circuit Resistor, R8*

### **Verification of Successful Installation**

1. Perform the “Turn-on (Cold-Start)” on page 4-2. The “Battery Requires Service” message should no longer be displayed on the power supply front panel.
2. Record the system data and compare with the data collected at the beginning of this procedure.
  - a. LBO temperature set point
  - b. Vanadate temperature set point
  - c. Etalon temperature set point
  - d. Diode #1 temperature set point
  - e. Diode #1 current
3. Reinstall the power supply top cover.
4. Verify the laser system is free of system faults.

### **Cleaning the Air Filter**

The air filter is located on the power supply rear panel as shown on Figure 4-3 on page 4-10.

## Criteria for Cleaning

Visually inspect the air filter on a periodic basis. Inspect more frequently if the operating environment is less than ideal.

Clean the air filter when the laser is turned off.



---

**Do not turn the power switch on the rear panel to the OFF position or disconnect the AC power input until the cool-down cycle is complete.**

---



---

**Do not remove the air filter while the fan is running. The fan is operational when the keyswitch is in the STANDBY position.**

---

### Preliminary steps

1. Perform the procedure in paragraph titled, "Turn-off (Complete Shut-down)" on page 4-5. The associated cool-down cycle will take approximately 45 minutes. The front panel display will indicate when the cool-down cycle is complete.
2. Turn the power switch on the power supply rear panel to the OFF position and disconnect the power cord from facility power.

### Air Filter Removal and Cleaning Procedure

3. Loosen the two retaining nuts (Figure 4-3, item 6) and remove the air filter.
4. Clean the air filter by rinsing with water and dry with a blower.
5. Re-install the air filter and retaining nuts. Perform the procedure in paragraph titled, "Turn-on (Cold-Start)" on page 4-2.

### Verification of Cleaning

6. Visually inspect the air filter to ensure the filter is free from visible contaminants.



## SECTION SEVEN: GENERAL OPERATING PRINCIPLES

### **Laser Head**

The Verdi V-2/V-5/V-6 laser resonator is a robust, unidirectional, single-frequency ring cavity design that employs intracavity, second harmonic generation to produce multi-watt-level continuous-wave green (532 nm) light output. Permanently aligned within a clean-room manufacturing environment, the resonator optics are mounted rigidly upon a proprietary grade Invar™ slab. The optics are mounted using Coherent's exclusive PermAlign™ manufacturing process, resulting in a permanently aligned resonator structure that is completely immovable — and stable.

Coherent-grade Super Invar™ combines a true zero coefficient of thermal expansion at room temperature with a high specific heat capacity, resulting in a resonator superstructure with extraordinary, passive thermal stability. The Invar slab is mounted kinematically to the laser head base plate, minimizing the influence of external mechanical forces upon the resonator alignment. The aligned assembly is housed within a sealed enclosure to isolate optical components from exposure to environmental contaminants.

Unidirectional oscillation in a ring laser resonator design is essential to establish and maintain reliable single-frequency operation through the elimination of spatial hole-burning. In Verdi, single-direction lasing is accomplished with an intracavity optical diode that induces lower losses for light traveling around the ring in the preferred direction, as opposed to the counter-propagating direction. The single-frequency selectivity associated with unidirectional oscillation is enhanced further with a temperature-stabilized intracavity etalon. The Verdi resonator also incorporates a Brewster-plate compensator to eliminate the astigmatism associated with the use of spherically curved mirror surfaces at non-normal incidence angles.

The Verdi resonator can be categorized as an “end-pumped” design, in which the pump light from the diode bar propagates collinear to the optical axis within the gain medium. Careful control of the spatial overlap between the mode volume defined by the resonator geometry and the actively pumped volume of the gain medium constrains laser oscillation to the lowest-order transverse mode ( $TEM_{00}$  mode operation). Transverse mode control is therefore achieved without the need for “hard” apertures that can introduce many undesirable characteristics, including beam distortions through diffraction effects, lowered efficiency, and lower pump-diode lifetimes.

## **Gain Medium**

The gain medium employed in Verdi is Nd:YVO<sub>4</sub> (neodymium-doped yttrium orthovanadate), also known as vanadate. Vanadate offers several significant advantages over alternative solid-state laser media common to diode-pumped lasers.

Neodymium ions doped into a vanadate host exhibit a comparatively large absorption coefficient centered at a wavelength convenient for readily available pump diode lasers. They are also spectrally broad, and therefore, insensitive to the precise wavelength or bandwidth of an optical pump source. Both of these characteristics contribute to ease-of-operation and the overall efficiency of diode-pumping.

In addition, vanadate exhibits strong intrinsic birefringence. This property eliminates the need for secondary means of polarizing the laser output and minimizes the consequences of thermally induced depolarization which may be encountered at high pump power density.

The characteristic lasing wavelength of neodymium-doped vanadate is nominally 1064 nm, in the near-infrared region of the optical spectrum. This infrared light is, in fact, the oscillating or “fundamental” wavelength of the Verdi resonator, rather than the visible green output associated with the device. The multilayer dielectric coatings of the four mirrors that define the ring resonator are designed to provide high reflectance centered at 1064nm to sustain circulating infrared power levels that typically exceed 100 watts. Converting a fraction of this circulating power into visible light is accomplished via the process of non-resonant, intracavity, second harmonic generation (SHG).

## **Second Harmonic Generator**

The nonlinear optical medium used for SHG in Verdi is the birefringent crystal lithium triborate (LBO). The efficiency of the SHG process (that is, how much power circulating within the resonator is converted from the infrared into visible light at precisely one half of the fundamental wavelength) is determined by the crystal orientation, as defined by the direction of light propagation, polarization state of the incident light, and the nominal crystal temperature. Given a fixed crystal orientation established during the initial construction of the resonator, temperature-tuning the refractive indices of the LBO provides a means of optimizing the SHG conversion efficiency.

The LBO doubler in Verdi is housed within an oven that is designed to maintain the crystal temperature at a typical value of 150°C. Given the proper crystal orientation and considering appropriate polarization states, the refractive indices of the birefringent crystal can be arranged to be identical for both the fundamental 1064nm

wavelength, and its second harmonic at 532nm for a temperature close to this value. When the “phase-matching” condition between the two different wavelengths implied by these considerations are satisfied, substantial power flow from the fundamental to the second harmonic is obtainable during a single pass through the doubler.

The particular crystal “cut” and temperature tuning scheme employed in the Verdi doubler is termed a Type I non-critical or 90° phase-matching scheme. In this scheme, both the infrared and green light beams are polarized linearly with orthogonal polarization states. The plane of polarization for the fundamental is parallel to the laser base plate, while the green polarization is perpendicular to it. Although the infrared and green beams are orthogonal in polarization, they propagate co-linearly and remain undistorted in profile as power is transferred from the fundamental to the second harmonic. The green light is separated from the circulating infrared light shortly after exiting the LBO crystal. The green light is then extracted from the resonator via a dichroic outcoupling mirror, which is coated to be highly reflecting at 1064nm, but essentially transparent at 532 nm.

The temperature dependence of the SHG process has important implications for the design and operation of the LBO oven servo. A change in the nominal temperature of only 1°C from the optimal value will cause a reduction in the conversion efficiency and subsequent laser output power of ~50%. Accordingly, the Verdi SHG crystal temperature is actively stabilized to a precision much better than 0.1°C.

In addition, because of otherwise insignificant variations in resonator alignment, crystal orientation, and oven construction, the highest efficiency doubler temperature can differ from unit to unit by a few degrees. Therefore, to determine the proper value for each system, each Verdi is optimized individually during the system integration phase of manufacturing.

## **Temperature Servos**

In addition to the SHG oven, the temperatures of two other optical components within the laser head are also monitored and stabilized actively by servo systems.

To maintain consistent coupling efficiency between the diode pump light and the neodymium ion absorbers, the temperature of the vanadate gain medium is held fixed at a nominal setting of ~30°C, independent of the pump power level. While this setting is adjustable, changes to the specified value of the vanadate temperature are unlikely necessary.

The intracavity etalon temperature is set to a nominal value that must fall within the range between 35°C and 75°C. As is the case for the LBO doubler, the value of the etalon temperature giving optimal laser performance can be expected to differ slightly from unit to unit and is subject to optimization during manufacture. The exact value therefore, has no intrinsic significance as long as the temperature remains well-stabilized and within the range of servo adjustment.

## **Output Optics**

A pair of high-reflectance beam-steering mirrors and a collimating lens are located external to the laser resonator, but still within the sealed resonator enclosure. To obtain good unit-to-unit reproducibility, the mirrors allow adjustment of the output beam position and pointing during the latter stages of the laser head manufacture. The optical power of the lens is selected and its precise positioning is adjusted to bring the output beam characteristic's spot size, divergence, waist location and astigmatism within specifications.

## **Power Monitor**

A silicon photodiode monitors the laser output to provide a continuous power level readout, as well as a servo feedback signal to establish the operating current of the diode bar(s). The beam is sampled and directed to the photodiode by the first-surface reflection from an uncoated fused-silica beam splitter. The beam splitter and photodiode are both located within the sealed resonator enclosure for protection from environmental disturbances or contaminants. The photodiode is insensitive to variations in the ambient temperature, avoiding one of the more common sources of error associated with light-sampling laser power servos.

## **Shutter**

A solenoid-actuated, remote-controlled mechanical shutter and beam dump mechanism is mounted within the laser head, external to the sealed resonator enclosure. This mechanism is intended to be used in conjunction with an external interlock circuit for laser operator safety – not as a process control device. Manual control of the shutter state is accomplished by a dedicated pushbutton located on the front panel of the power supply, or the shutter can be accessed remotely via commands issued through the RS-232 serial port. The shutter is designed as a “fail-closed” mechanism that completely blocks the exit aperture of the laser head unless the solenoid is energized.

## **Heat Sinking**

Depending upon the specific laser model and the actual operating conditions encountered, a Verdi laser head can generate tens of watts of “waste” heat that must be properly managed to maintain optimal laser performance. Essentially, all of this heat must flow through the base plate with comparatively negligible heat transfer through either the top or the sides of the head. The base plate is machined flat to tight tolerances in anticipation of minimizing the thermal impedance between the head and an underlying heat spreader or heat sink by maximizing the available contact area.

The laser head base plate temperature is monitored by the operating system and can be displayed on the front panel of the power supply or reported via RS-232. The system will declare a fault condition and shut down when the base-plate temperature exceeds 55°C.

Simple heat-transfer considerations dictate the temperature of the mounting surface beneath the laser head and must be held at a value lower than the fault set-point to sustain heat flow out of the head. When securing a laser head directly upon the Coherent-supplied riser block, the maximum temperature of the upper surface block will typically tolerate 45°C before a temperature fault is registered by the system.

A significant benefit of using the water-cooled riser in conjunction with the water chiller is the minimization of any changes in beam pointing associated with temperature changes in the mounting scheme. This becomes important for applications that are sensitive to beam-pointing errors, such as launching the Verdi output into a single-mode optical fiber, or pumping a Ti:sapphire laser, especially if ambient conditions are subject to uncontrolled fluctuations.

## **Umbilical**

The umbilical is permanently attached to the laser head and is not intended to be removed from the head. It houses the optical fibers that deliver pump power to the head as well as several electrical cables that carry electrical power and various signals between the power supply and the head. The umbilical is designed to provide protection from mechanical abrasion and to maintain a safe minimum bend radius for the optical fibers.

The laser head, umbilical, and power supply are connected together and shipped by Coherent as an integrated unit. Disconnection of the umbilical from the power supply should only be attempted under the supervision of trained personnel. Care should be taken during system installation to avoid excessive twisting or kinking of the umbilical which might damage the internal components.

## Power Supply

- The Verdi power supply houses several circuit boards:
- A switching electrical power supply rated at 1/2-kilowatt DC
- A lead-acid storage battery that provides emergency backup electrical power
- One laser diode bar assembly along with appropriate means of heat-sinking the assembly.

### **The power supply addresses several specific functions:**

- Generation of wavelength-optimized optical pump energy to be delivered to the gain medium within the laser resonator situated in the laser head
- Provision of a full-function user interface, completely accessible from the front panel or remotely through an RS-232 serial port interface
- Implementation of the monitoring and control servo loops required for operation of the laser system

## Laser Diode

The laser diode bar assembly employed as a pump source in Verdi is designated by the acronym FAP-I™ (Fiber Array Package – Integrated).

Housed within the FAP-I are the following components:

- A sealed diode bar sub-assembly, incorporating a close-coupled array of 19 optical fibers. These optical fibers efficiently address the light output from the various discrete emitters on the bar and into a single output port
- Several large thermo-electric coolers to control the temperature and therefore the emission wavelength of the diode bar
- Various signal conditioning and monitoring electronics
- Several other essential electrical connectors

The laser diode bar within the FAP-I efficiently converts low-voltage high-current electrical power into tunable laser light. Electrical-to-optical conversion efficiencies typically approach 50%, with the non-radiated power contributing primarily to heating of the device. The coupling efficiency obtained in launching light from the bar through the fiber array and into a single transport fiber is conservatively specified to be no less than 80%, with typical values exceeding 90%.

The emission bandwidth of diode bars is typically between 2nm and 4nm (full width half maximum). When the nominal wavelength is centered on the strong absorption band associated with neodymium ions in a vanadate host, more than 90% of the incident diode laser light can be absorbed readily in only a few millimeters of crystal to generate high optical gain within a small volume. The tuning rate of diode bars as a function of operating temperature is typically 0.3 nm/°C. Higher temperatures imply longer wavelengths. The temperature of the FAP-I in Verdi is individually monitored and adjusted to optimize the coupling efficiency. Optimum efficiency is typically obtained when the nominal operating temperature falls within the range of 5°C to 35°C.

The optical output power of diode laser bar is linearly proportional to drive current above a threshold lasing level that is at least several amps in magnitude, but generally does not exceed 15 amps. Conversely, when the drive current is increased to a value several times greater than the lasing threshold, the electrical-to-optical conversion efficiency eventually begins to deteriorate and a noticeable departure from linearity in the output becomes evident. With a further increase in current, catastrophic failures may occur and the bars can be damaged permanently. The Verdi operating system is designed to maintain diode bar operation well within the linear output regime and prohibits damage due to excessive diode current.

Laser diode bars tend to exhibit a couple of characteristic changes in performance as a consequence of aging.

1. Diode bars often experience a slow decay in efficiency usually associated with an accumulation of optical or electrical defects within the material of the bar or upon its surfaces. If constant output power is desired, the deterioration can be offset by compensating increases in drive current, which is still well within the operating regime. Verdi handles this issue without any need for operator intervention.
2. The nominal wavelength of a diode bar tends to “red shift” over the life of a bar, requiring re-optimization of the operating temperature to somewhat lower values and maintain a specific wavelength. To compensate for possible changes in diode wavelength, Verdi has an on-demand temperature optimization. See “LBO Temperature Optimization” on page 6-40 for the optimization procedure.

Both strategies are designed to ensure thousands of hours of operation free from the need of other corrective actions.

Laser diode modules represent the only consumable components in Verdi that should be explicitly recognized when establishing maintenance schedules. See “Troubleshooting/Fault Messages” on

page 6-1 for appropriate procedures to determine when a module may be approaching the point where replacement is indicated. Also, refer to the procedure in paragraph titled, "FAP-I Replacement" on page 6-22 for complete replacement details.

## **Battery Backup**

The lead-acid storage battery in the Verdi power supply provides a backup electrical current source to allow the system to execute a graceful shutdown in the event that AC power is prematurely terminated during system operation. The battery is continuously trickle-charged during normal system operation and will automatically recharge itself after being depleted. Status of the battery is accessible from both the front panel and through serial port queries.

Activation of a secondary microprocessor occurs automatically if AC power is lost when the system is in either STANDBY or ON key-switch modes when the AC power switch is ON. The primary function of this processor is to ensure that the temperature of the LBO doubling crystal is ramped down in a controlled fashion to avoid any risk of thermal shock or coating damage. The battery stores sufficient energy to continue supplying power to the secondary microprocessor and the doubler oven throughout the time required to bring the temperature down from its nominal operating value to room temperature (typically ~30 minutes).

## **Cooling Issues**

The Verdi power supply is cooled by air. A large-ducted fan pulls air through a dust filter and drives air flow through a finned heat sink situated directly beneath the diode bar module.

The dust filter must be inspected periodically to verify free air flow. For cleaning procedures, see "Cleaning the Air Filter" on page 6-45.

The heat-sink temperature can be monitored from the front panel of the panel supply in the Laser Status Screen, or queried via the RS-232 port. A fault condition will be declared if the heat sink temperature exceeds 65°C.



## PACKING PROCEDURE

The following is the factory-recommended packing procedure for the Verdi V-2/V-5/V-6 laser systems. This procedure must be followed if the laser system is to be shipped to another location after initial installation.

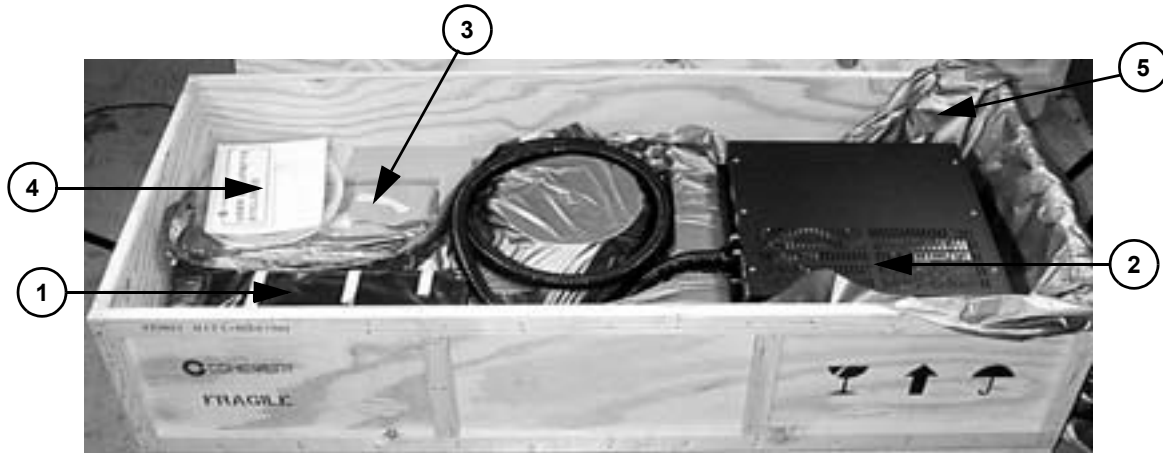
The Verdi V-2/V-5/V-6 laser systems requires one Coherent-supplied shipping crate, part number 0171-654-00. Table A-1 gives a complete listing of the contents of the shipping crate when the system is shipped from Coherent.

The Verdi V-2/V-5/V-6 laser systems crate consists of a single-molded foam compartment. Figure A-1 illustrates the proper placement of each of the components listed in Table A-1. To prevent ESD damage, the compartment should be lined with anti-static material before placing the laser head and power supply into the crate. Enough anti-static material should be used so the excess can be folded over to cover the top of the power supply after the crate is completely packed. See Figure A-2.

**Table A-1. Verdi V-2/V-5/V-6 Laser Shipping Crate Contents**

1.	Laser Head
2.	Power Supply
3.	Riser/Heat Sink
4.	Installation Kit
a.	System Fuses: 15A 250V (2x) and 10A 250V (2x)
b.	Diode Shorting Clips (2x)
c.	Fiber Optic Cable End Caps (2x)
d.	Diode Fiber Connector End Caps (2x)
e.	External Interlock Plug, Shorted
f.	External Interlock Plug, Disassembled.
g.	1/4 inch Water Tubing
h.	Tubing Connectors
i.	Laser Head/Riser/Heat Sink Clamps (4x)
j.	Riser/Heat Sink/Stable Table Clamps (4x)
k.	Final Test Data Sheet
5.	Static Wrap Liner

Note that the riser/heat sink, system documentation, and the accessories package should be placed under the anti-static liner and that the laser head is separately wrapped in anti-static material (see Figures A-1 and A-2).



- |                    |                      |
|--------------------|----------------------|
| 1. Laser Head      | 4. Installation Kit  |
| 2. Power Supply    | 5. Static Wrap Liner |
| 3. Riser/Heat Sink |                      |

**Figure A-1. Packed Verdi V-2/V-5/V-6 Laser Shipping Crate**

Due to the weight of the system, Coherent recommends three people for packing the Verdi V-2/V-5/V-6. The laser head and power supply are connected by the umbilical. The umbilical should be wound loosely in the foam cutout as illustrated in Figure A-3 to prevent damage to the fiber optic delivery cables running between the head and the power supply.



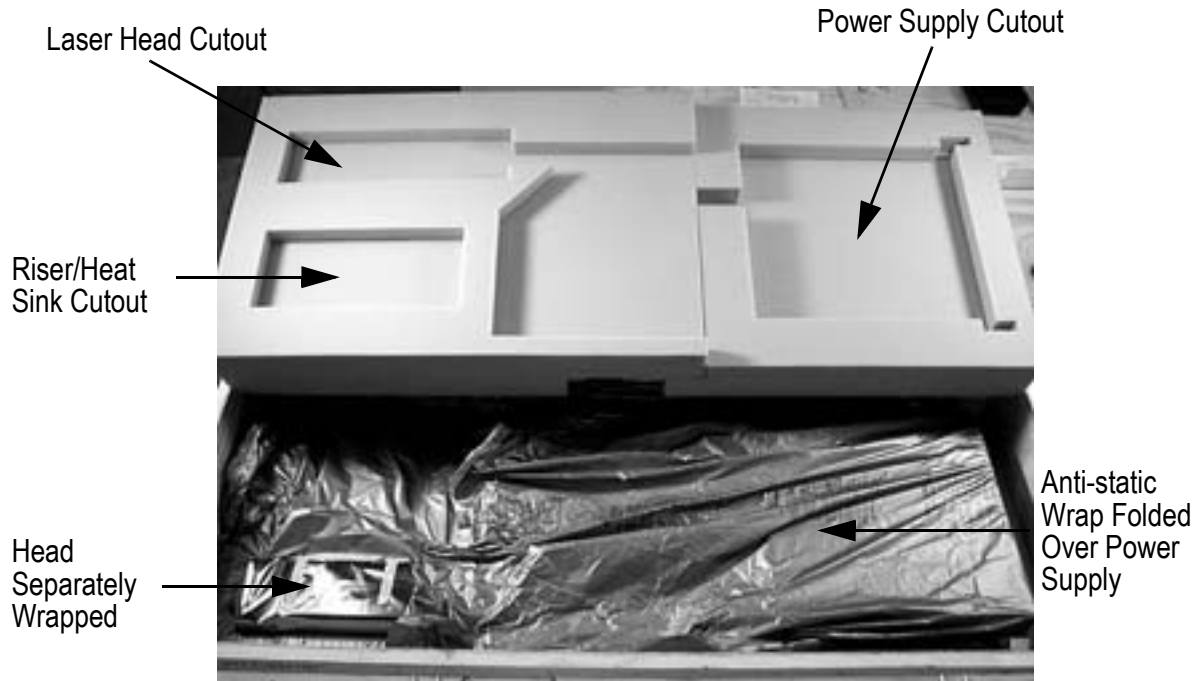
---

**Excessively tight umbilical bends (less than a 5 inch radius) can cause permanent damage to the fiber optic cables.**

---

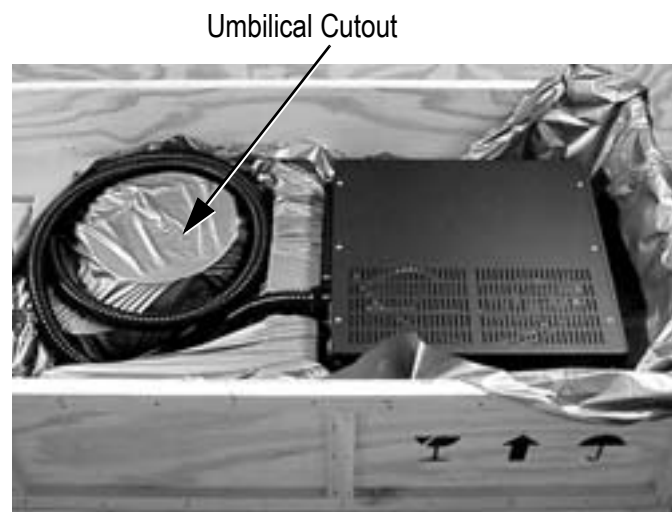
Place the Verdi V-2/V-5/V-6 in the shipping crate as follows:

1. Place the power supply in the cutout as shown in Figure A-1.
2. A second person carrying the laser head should walk clockwise around the shipping container while the first person guides the umbilical onto the cutout as shown in Figure A-1.
3. Place the laser head into the cutout.



**Figure A-2. Top Foam for Verdi V-2/V-5/V-6 Laser Shipping Crate**

4. Position the top foam onto the crate as in Figure A-2.
5. Place the Verdi V-2/V-5/V-6 Maintenance Kit in the outer cutout as in Figure A-4.
6. Attach the crate lid.



**Figure A-3. Proper Packing of System Umbilical**

Maintenance Kit Cutout



***Figure A-4. Location of Packed Verdi V-2/V-5/V-6 Laser Maintenance Kit***

# PARTS LIST

DESCRIPTION	PART NUMBER
Replacement FAP-I Kit	V2: 0175-589-00 V5: 1037865 V6: 1036352
Fuses: 10 A 250 V 15 A 250 V 4 A, 250 V 7 A, 250 V	5100-0072 5110-0002 5110-0088 5110-0241
FAP-I Shorting Clip	0171-588-00
FAP-I Fiber Port Cover with chain	2105-0161
Fiber Dust Cap (blue)	1404-0169
External Interlock Plug	0171-642-00
Head Mounting Clamp and Pin Kit	0172-826-00
Shipping Crate (System)	0171-654-00
Rack Mount Kit	0172-720-00
Riser/Heat Sink (Passive)	0171-530-00
Riser/Heat Sink (Water-cooled) Kit	0171-531-00
Water Chiller	1037271
Power Cord, 13A, 125 V, 10 ft.	6005-0145
Power Cord, 13A, 125 V, 10 ft., No Plug	6005-0146
Air Filter	0170-382-00
Battery	4002-0031
Power Supply Keys, Set of Two	5107-0143



## ACCESSORIES

### Power Meters and Sensors

Coherent offers a variety of instruments for laser test and measurement. For additional detailed information, including product selection guides, please visit our web site at [www.Coherent.com](http://www.Coherent.com).

For the most common diagnostics, Coherent recommends the FieldMax-Top™ power meter with a PM30 power sensor to measure the output of the Verdi. The PM30 is ideal for the entire Verdi product family.

### Recommendation

Below, is a great product combination covering the 0.19  $\mu\text{m}$  to 11  $\mu\text{m}$  wavelength range for all Verdi power levels. The power meter is a versatile, easy to use digital meter designed for field service and production applications. The power sensors are air-cooled, surface absorbing and intended for low to medium Pulsed and CW powers.



FieldMax-Top™ Power Meter Part Number 0012-3790	PM30 Power Sensor (up to 50 Watts) Part Number 0012-1160
--	---





## WARRANTY

Coherent, Inc. warrants Diode-Pumped Solid State laser systems to the original purchaser (the Buyer) only, that the laser system, that is the subject of this sale, (a) conforms to Coherent's published specifications and (b) is free from defects in materials and workmanship.

Laser systems are warranted to conform to Coherent's published specifications and to be free from defects in materials and workmanship for a period of 12 months or 5000 hours of operation, whichever occurs first.

### **Responsibilities of the Buyer**

The buyer is responsible for providing the appropriate utilities and an operating environment as outlined in the product literature. Damage to the laser system caused by failure of buyer's utilities or failure to maintain an appropriate operating environment, is solely the responsibility of the buyer and is specifically excluded from any warranty, warranty extension, or service agreement.

The Buyer is responsible for prompt notification to Coherent of any claims made under warranty. In no event will Coherent be responsible for warranty claims made later than seven (7) days after the expiration of warranty.

### **Limitations of Warranty**

The foregoing warranty shall not apply to defects resulting from:

- Components and accessories manufactured by companies, other than Coherent, which have separate warranties,
- Improper or inadequate maintenance by the buyer,
- Buyer-supplied interfacing,
- Operation outside the environmental specifications of the product,
- Unauthorized modification or misuse,
- Improper site preparation and maintenance, or
- Opening the pump laser head housing.

Coherent assumes no liability for customer-supplied material. The obligations of Coherent are limited to repairing or replacing, without charge, equipment which proves to be defective during the warranty period. Replacement sub-assemblies may contain reconditioned

parts. Repaired or replaced parts are warranted for the duration of the original warranty period only. The warranty on parts purchased after expiration of system warranty is ninety (90) days. Our warranty does not cover damage due to misuse, negligence or accidents, or damage due to installations, repairs or adjustments not specifically authorized by Coherent.

Warranty applies only to the original purchaser at the initial installation point in the country of purchase, unless otherwise specified in the sales contract. Warranty is transferable to another location or to another customer only by special agreement which will include additional inspection or installation at the new site. Coherent disclaims any responsibility to provide product warranty, technical or service support to a customer that acquires products from someone other than Coherent or an authorized representative.

THIS WARRANTY IS EXCLUSIVE IN LIEU OF ALL OTHER WARRANTIES, WHETHER WRITTEN, ORAL OR IMPLIED, AND DOES NOT COVER INCIDENTAL OR CONSEQUENTIAL LOSS. COHERENT SPECIFICALLY DISCLAIMS THE IMPLIED WARRANTIES OF MERCHANTABILITY AND FITNESS FOR A PARTICULAR PURPOSE.

# GLOSSARY

°C	Degrees centigrade or Celsius
°F	Degrees Fahrenheit
μ	Microns
μrad	Microradian(s)
μsec	Microsecond(s)
1/e <sup>2</sup>	Beam diameter parameter
AC	Alternating current
Amp	Amperes
CDRH	Center for Devices and Radiological Health
CFR	Code of Federal Regulation
cm	Centimeter(s)
DC	Direct current
EEPROM	Electrically erasable programmable read only memory
EMC	Electromagnetic Compliance
FAP-I™	Fiber array package-integrated
FSR	Free spectral range
I/O	Input/output
kg	Kilogram(s)
LBO	Lithium Triborate, LiB <sub>3</sub> O <sub>5</sub>
LD	Laser diode
LED	Light emitting diode
LVD	Low Voltage Directive
m	Meter(s)
mAmp	Milliampere(s)
MHz	Megahertz
mm	Millimeter(s)
mrad	Milliradian(s)
msec	Millisecond(s)
mV	Millivolt(s)
mW	Milliwatt(s)
Nd:YAG	Neodymium:Yttrium Aluminum Garnet
Nd:YVO	Neodymium:Yttrium Orthovanadate
nm	Nanometer(s)
OEM	Original equipment manufacturer
rms	Root mean square
TEC	Thermo-electric cooler
TEM	Transverse Electromagnetic Mode (cross-sectional laser beam mode)
VAC	Volts, alternating current
VDC	Volts, direct current
W	Watt(s)



# INDEX

## A

AC ON indicator does not light 6-10  
Air filter 4-10, 4-11

## B

Baseplate temperature fault 6-16  
Battery replacement 6-42

## C

CDRH compliance  
    Beam attenuator 1-3  
    Laser classification 1-2  
    Laser radiation emission indicators 1-3  
    Operating controls 1-3  
    Protective housing 1-3  
Cleaning the air filter 6-45  
Cleaning the optical transport fiber end face 6-40  
Computer 5-1  
Computer control (see external computer control)  
Controls, indicators, and features 4-6

## D

Description  
    Laser head 2-2  
    Power supply 2-3  
    Riser/heat sink 2-1  
    Umbilical 2-1  
Dimensions  
    Laser head (diagram) 3-9  
    Power supply (diagram) 3-10  
Diode EEPROM fault 6-20  
Diode heat sink  
    (Power supply) temperature fault 6-17  
Diode over current fault 6-18  
Diode over voltage fault 6-20  
Diode temperature fault 6-15  
Diode under voltage fault 6-20  
Diode/heat sink temperature 2-4

## E

Emission indicator 4-7  
Environmental requirements 3-9  
    Altitude 3-9  
    Operating temperature 3-9  
    Relative humidity 3-9

## Etalon

    Temperature 2-4  
    Temperature fault 6-15

Exit window 4-7

External computer control  
    Interface to the Verdi 5-1

    Response from Laser after Receiving  
        Instruction 5-2

    RS-232 command language 5-1

    RS-232 Commands 5-5

    RS-232 Queries 5-6

External interlock 3-7

External interlock fault 6-13

## F

FAP-I replacement 6-22  
    FAP-I anode/cathode shorting clip 6-24  
    FAP-I assembly interface 6-26  
    FAP-I fiber optic connector 6-27  
    FAP-I handling precautions 6-23  
    FAP-I installation 6-27  
    FAP-I removal 6-25  
    Fiber cable handling precautions 6-24  
    Fiber optic cap 6-24  
    Preliminary steps and data 6-22  
    Preparation of the replacement FAP-I  
        assembly 6-28  
Fault handling 4-13  
Fault messages 6-1

## G

Gain medium 2-2, 2-3  
    Etalon 2-4  
    Vanadate 2-4  
Glossary Glossary-1

## H

Head interlock fault 6-12  
Head-diode mismatch fault 6-20  
Heat sink/riser (see Riser/heat sink)

## I

Initial turn-on procedures 3-6  
Installation 3-1  
    Dimensions 3-9  
    Environmental requirements 3-9  
    External interlock 3-7  
    Initial turn-on procedures 3-6  
    Installation kit 3-1, 3-2  
    Laser head 3-1  
    Laser head base 3-4  
    Power supply 3-5  
    Receiving and inspection 3-1  
    Utility requirements 3-8  
Installation kit 3-1, 3-2  
Installing the laser head 3-1  
Installing the power supply 3-5

Instruction set 5-4  
Instruction syntax for RS-232 communication 5-1  
Interconnect diagram 3-8  
Interface to The Verdi 5-1  
Interlock 3-7

## K

Key switch 4-9

## L

Laser diode assembly 2-4  
Laser does not start 6-4  
Laser head 2-2  
    Dimensions (diagram) 3-9  
    EEPROM fault 6-20  
    Installation 3-1  
    Optical schematic 2-3  
Laser head base 3-4  
Laser head dimensions (diagram) 3-9  
Laser output unstable 6-8  
Laser Safety (see Safety)  
Laser shuts down 6-6  
LBO  
    Not locked at set temperature 6-20  
    Optimization error message 6-41  
    Temperature 2-3  
    Temperature fault 6-15  
    Temperature optimization 6-40  
Light loop 2-3  
Line voltage requirements 3-8  
Low power warning 4-14

## M

Maintenance and service 6-1  
Menu displays 4-12

## O

Operation 4-1  
    Fault handling 4-13, 4-14  
    Menu displays 4-12  
    Operating States 4-1  
    Turn-off (Complete shut-down) 4-5  
    Turn-off (Daily use) 4-4  
    Turn-on (Cold start) 4-2  
    Turn-on (Daily warm-start) 4-3  
Operations  
    Menus 4-12  
Optical diode 2-3  
Optical schematic 2-3  
Over current fault 6-18

## P

Packing procedure A-1  
    Location of packed Verdi maintenance kit A-4  
    Packed Verdi shipping crate A-2  
    Proper packing of system umbilical A-3  
    Top foam for Verdi shipping crate A-3

Verdi shipping crate contents A-1  
Parts list B-1  
    Fuse B-1  
    Rack mount kit B-1  
    Riser/heat sinks (passive) B-1  
    Riser/heat sinks (water-cooled) B-1  
    Shipping crate (system) B-1  
Power cord 4-11  
Power supply 2-3  
    EEPROM fault 6-20  
    Head mismatch fault 6-20  
    Installation 3-5  
    Interlock fault 6-14  
    Laser diode assembly 2-4  
    Servo loops 2-3  
        Diode/heat sink temperature 2-4  
        LBO temperature 2-3  
        Light loop 2-3  
        Vanadate and etalon temperature 2-4  
Power supply dimensions (diagram) 3-10

## R

Radiated emission compliance 1-3  
Receiving and inspection 3-1  
Riser/heat sink 2-1, 3-4, 4-7  
    (Power supply) temperature fault 6-17  
    Installation 3-4  
RS-232

    Command language 5-1  
    ECHO mode 5-2  
    PROMPT mode 5-2  
    Commands 5-5  
    Instruction syntax communications 5-1  
    Interface connection 5-3  
    Pin configuration 5-4  
    Port configuration 5-3  
    Port description 5-3  
    Queries 5-6

## S

Safety  
    Features and compliance to Government requirements 1-2  
    Features and compliance to government requirements 1-2  
    Features and labels, location of 1-4  
    Labels, location of 1-3  
    Optical Safety 1-1  
    Optical safety 1-1  
Safety labels, location of 1-3  
Setting the baud rate 5-3  
Shutter state mismatch 6-20  
Specifications 2-5  
    Beam diameter 2-5  
    Beam divergence 2-5  
    Linewidth 2-5

- Noise 2-5
  - Pointing Stability 2-5
  - Polarization 2-5
  - Power 2-5
  - Power stability 2-5
  - Wavelength 2-5
  - System description 2-1
  - System Status Messages 4-12
- T**
- Troubleshooting 6-1
    - AC ON indicator does not light 6-10
    - Baseplate temperature fault 6-16
    - Battery replacement 6-42
    - Cleaning the air filter 6-45
    - Diode EEPROM fault 6-20
    - Diode heat sink temperature fault 6-17
    - Diode over current fault 6-18
    - Diode over voltage fault 6-20
    - Diode temperature fault 6-15
    - Diode under voltage fault 6-20
    - Etalon temperature fault 6-15
    - External interlock fault 6-13
    - FAP-I replacement 6-22
    - Fault messages 6-1
    - Head interlock fault 6-12
    - Head-diode mismatch fault 6-20
    - Laser does not start 6-4
    - Laser head EEPROM fault 6-20
    - Laser output unstable 6-8
    - Laser shuts down 6-6
    - LBO not locked at set temperature 6-20
    - LBO temperature fault 6-15
    - LBO temperature optimization 6-40
    - No light output 6-4, 6-6
    - Over current fault 6-18
    - Power supply EEPROM fault 6-20
    - Power supply interlock fault 6-14
    - Power supply-head mismatch fault 6-20
    - Riser/heat sink temperature fault 6-17
    - Shutter state mismatch 6-20
    - Vanadate temperature fault 6-15
  - Turn-off (see Operation)
  - Turn-on 4-2, 4-3, 4-4, 4-5
  - Turn-on (see Operation)
- U**
- Umbilical 4-7
  - Utility requirements 3-8
    - Cooling 3-8
    - Maximum current 3-8
    - Power requirements 3-8
- V**
- Vanadate (see Gain medium)
  - Vanadate temperature fault 6-15
- W**
- Warranty D-1







*Verdi V-2/V-5/V-6 Lasers Operator's Manual*  
© Coherent, Inc. 08/2005, Printed in the U.S.A.  
Part No. 0171-750-00, Rev IB